



**DELTA TAU**  
Data Systems, Inc.

*NEW IDEAS IN MOTION...*

## **USER MANUAL**

# **ACCESSORY 24E2A**

## **Axis Expansion Board**



*Part No. xxx-603398-10x*

*February 23, 2001*

[RETURN TO  
MAIN INDEX](#)



**Power // Flexibility // Cost Effectiveness // Customer Service // Ease of Use**

21314 Lassen Street Chatsworth, CA 91311 // Tel. (818) 998-2095 Fax. (818) 998-7807 // [www.deltatau.com](http://www.deltatau.com)



## CONTENTS

<b>INTRODUCTION.....</b>	<b>1</b>
OVERVIEW.....	1
FEATURES.....	2
BOARD CONFIGURATION .....	2
ACC-24E2 POWER SUPPLY REQUIREMENTS.....	3
OPTO-ISOLATION CONSIDERATIONS.....	3
<b>ACC24-E2A BOARD LAYOUT.....</b>	<b>5</b>
<b>E-POINT JUMPER SETTINGS.....</b>	<b>7</b>
ACC-24E2A BASE BOARD (CHANNELS* 1 & 2).....	7
ACC-24E2A OPTION 1 BOARD (CHANNELS 3 & 4).....	8
<b>HARDWARE SETUP.....</b>	<b>9</b>
POSITION COMPARE PORT DRIVER IC .....	9
SWITCH CONFIGURATION .....	9
UMAC Address DIP Switch S1.....	9
MACRO Station Address DIP Switch S1 .....	10
RESISTOR PACK CONFIGURATION.....	10
Termination Resistors.....	10
ACC-24E2 LIMIT AND FLAG WIRING .....	11
ACC-24E2 Limit/Flag Circuit.....	11
Connecting Limits/Flags to the ACC-24E2 .....	12
AMPLIFIER FAULT CIRCUIT.....	13
LOSS OF ENCODER CIRCUIT .....	13
ACC-24E2 CLOCK SETTINGS.....	14
<b>UMAC SOFTWARE SETUP.....</b>	<b>15</b>
SYSTEM CONFIGURATION I-VARIABLES .....	15
SERVO IC CONFIGURATION I-VARIABLES.....	15
Servo IC Numbering .....	15
Servo Channel Numbering .....	16
Multi-Channel I-Variables.....	16
Single-Channel I-Variables.....	17
Encoder Conversion Table I-Variables .....	17
Motor Addressing I-Variables.....	18
UMAC TURBO EXAMPLE SETUPS .....	23
<b>ULTRALITE/MACRO STATION SETUP.....</b>	<b>25</b>
HARDWARE SETUP FOR MACRO STATION USE.....	25
SOFTWARE SETUP FOR MACRO STATION USE.....	25
Node-Specific Gate Array MI-variables.....	26
Encoder/Timer n Decode Control (MSn, MI910).....	26
Flag Capture Control (MSn, MI911–MI913).....	27
Output Mode Select (MSn, MI916) .....	28
MACRO Station Encoder Conversion Table (MSn, MI120–MI151).....	29
<b>MLDT FEEDBACK FOR UMAC-TURBO &amp; UMAC-MACRO.....</b>	<b>31</b>
MLDT HARDWARE SETUP OF THE ACC-24E2A.....	31
MLDT SOFTWARE SETUP OF THE UMAC TURBO.....	31

<i>Hardware Setup I-Variables for Servo IC m</i> .....	31
<i>Conversion Table Processing I-Variables</i> .....	32
<i>Motor I-Variables</i> .....	33
<i>Pulse Output Frequency</i> .....	33
<i>PMAC2/Turbo PMAC2 Conversion Table &amp; Motor I-variables</i> .....	35
<b>MLDT FEEDBACK FOR UMAC-MACRO</b> .....	37
<i>MLDT Software Setup of the UMAC MACRO</i> .....	37
<i>Station Hardware Setup I-Variables for Servo IC</i> .....	37
<i>Station Conversion Table Processing I-Variables</i> .....	37
<i>Station Motor Node I-Variables</i> .....	38
<i>Power-On Feedback Address for PMAC2 Ultralite</i> .....	39
<i>MACRO Parallel Absolute Position Setup</i> .....	40
<b>ACC-24E2A TERMINAL BLOCK DESCRIPTION</b> .....	<b>43</b>
CONNECTOR TB1 TOP - ENCODER 1.....	43
CONNECTOR TB2 TOP - ENCODER 2.....	44
CONNECTOR TB3 TOP – EQU OUTPUTS.....	44
CONNECTOR TB1 BOTTOM AMP – OUT 1.....	44
CONNECTOR TB2 BOTTOM AMP – OUT 2.....	45
CONNECTOR TB3 BOTTOM – ANALOG POWER.....	45
CONNECTOR TB1 FRONT- LIMITS 1.....	45
CONNECTOR TB2 FRONT- LIMITS 2.....	46
<b>ACC-24E2 OPTION 1A TERMINAL BLOCK DESCRIPTION</b> .....	<b>47</b>
CONNECTOR TB1 TOP - ENCODER 3.....	47
CONNECTOR TB2 TOP – ENCODER 4.....	48
CONNECTOR TB3 TOP – EQU OUTPUTS.....	48
CONNECTOR TB1 BOTTOM AMP-OUT 3.....	49
CONNECTOR TB2 BOTTOM AMP-OUT 4.....	49
CONNECTOR TB3 BOTTOM-ANALOG POWER.....	50
CONNECTOR TB1 FRONT - LIMITS 3.....	50
CONNECTOR TB2 FRONT - LIMITS 4.....	50
<b>UBUS PINOUTS</b> .....	<b>51</b>
P1 UBUS (96-PIN HEADER).....	51
<b>SCHEMATICS</b>	
Sheet 1	
Sheet 2	

## INTRODUCTION

---

---

### Overview

---

The ACC-24E2 Axis Expansion Board provides two or four channels of PMAC2-style servo interface circuitry for UMAC and Ultralite/MACRO Station controllers. The ACC-24E2 is part of the UMAC or MACRO Pack family of expansion cards and these accessory cards are designed to plug into an industrial 3U rack system. The information from these accessories is passed directly to either the UMAC or MACRO Station CPU via the high speed JEXP expansion bus. Other axis or feedback interface JEXP accessories include the following:

- ACC-14E Parallel Feedback Inputs (absolute enc. or interferometers)
- ACC-24E2 Digital Amplifier Breakout w/ TTL encoder inputs
- ACC-24E2A Analog Amplifier Breakout w/ TTL encoder inputs
- ACC-24E2S Stepper Amplifier Breakout w/ TTL encoder inputs
- ACC-28E 16-bit A/D Converter Inputs (up to four per card)
- ACC-51E 4096 times interpolator for 1Vpp sinusoidal encoders
- ACC-53E SSI encoder interface (up to 8 channels)

---

#### *Note:*

Many ACC-24E2A features are common to other accessories of the ACC-24E family; these common features are identified in this manual as “ACC-24E2.”

---

Up to eight ACC-24E2 boards can be connected to one UMAC, providing up to 32 additional channels of servo interface circuitry. Because each MACRO Station CPU can service only eight channels of servo data, only two ACC24E2 boards can be connected to the MACRO Station.

The ACC-24E2 board contains no processor; it has 1 highly integrated 4-channel PMAC2-style “Servo IC” with the buffering circuitry and connectors around them. The two-axis ACC-24E2 plugs into the backplane and uses one slot in the Rack. If the user needs two more axes, ACC-24E2 option 1 can be plugged into the ACC-24E2 connectors. The ACC-24E2 with its option1 card take up a total of two slots.

Some new features added to the family of ACC-24E2 breakout boards include:

- Loss of encoder circuit
- 5V to 24V Flag inputs
- Pulse and direction outputs for stepper systems or MLDTs

## Features

---

The ACC-24E2A board can be used with any UMAC or MACRO Station CPU, interfacing through the expansion port.

The ACC-24E2A supports a wide variety of servo and stepper interfaces:

- Analog +/-10V velocity commands
- Analog +/-10V torque commands
- Sinusoidal analog +/-10V phase current commands
- Pulse-and-direction commands

## Board Configuration

---

An ACC-24E2 comes standard with one Servo IC providing four servo interface channels, which are brought out on terminal blocks and mini D-Sub connectors. Each channel of servo interface circuitry includes the following:

- 2 output command signal sets, configurable as either:
  - 1 pulse-and-direction
  - 2 DAC outputs
- 3-channel differential/single-ended encoder input
- 8 input flags, 2 output flags

**Option 1A:** If Option 1A is ordered, the circuitry and input/output connectors are provided for the 3<sup>rd</sup> and 4<sup>th</sup> channels associated with the Servo IC on the main ACC-24E2A. The command signals for this option are  $\pm 10V$ .

**Option 1D:** If Option 1D is ordered, the circuitry and input/output connectors are provided for the 3<sup>rd</sup> and 4<sup>th</sup> channels associated with the Servo IC on the main ACC-24E2A. The command signals for this option are digital PWM signals for direct PWM commutation. The option 1D description can be found in the ACC-24E2 manual.

## ACC-24E2 Power Supply Requirements

The following table lists the power requirements for the entire ACC-24E2 family of products for the UMAC-Turbo and UMAC-MACRO. Because of the flexibility of these products, we have listed the power requirements for all ACC-24E products.

Product	5V	12V for DAC's	-12V for DAC's	12V-24V for Flag Circuits
ACC-24E2	700mA	N/A	N/A	
ACC-24E2 opt 1	200mA	N/A	N/A	
ACC-24E2A	800mA	200mA	200mA	
ACC-24E2 opt. 1A	200mA	200mA	200mA	
ACC-24E2S	600mA	N/A	N/A	

## OPTO-ISOLATION CONSIDERATIONS

As shipped from the factory, the ACC-24E2A obtains it's power from the UMAC Backplane or UBUS. Using this type of setup will defeat opto isolation since the analog ground plane will be tied directly to the digital ground plane.

If the user wants to optically isolate the analog ground plane from the digital ground plane, they will have to connect an external power supply to one of the many AA+15V, AA-15V, and AAGND inputs on the ACC-24E2A terminal blocks. The user must also remove the E85, E87, and E88 jumpers to isolate the external power from the UBUS power supplies.

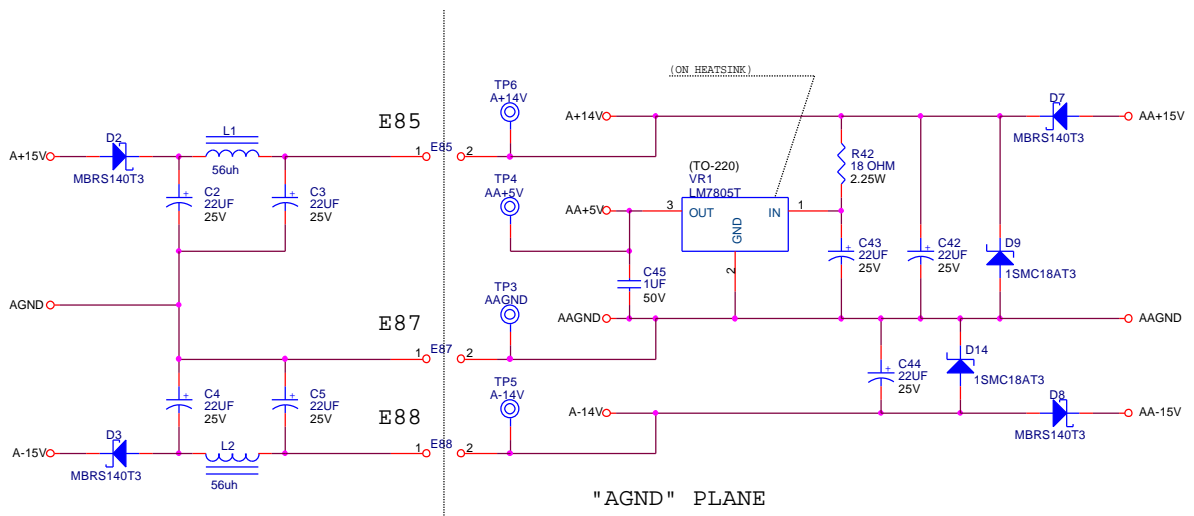



## ACC24-E2A BOARD LAYOUT

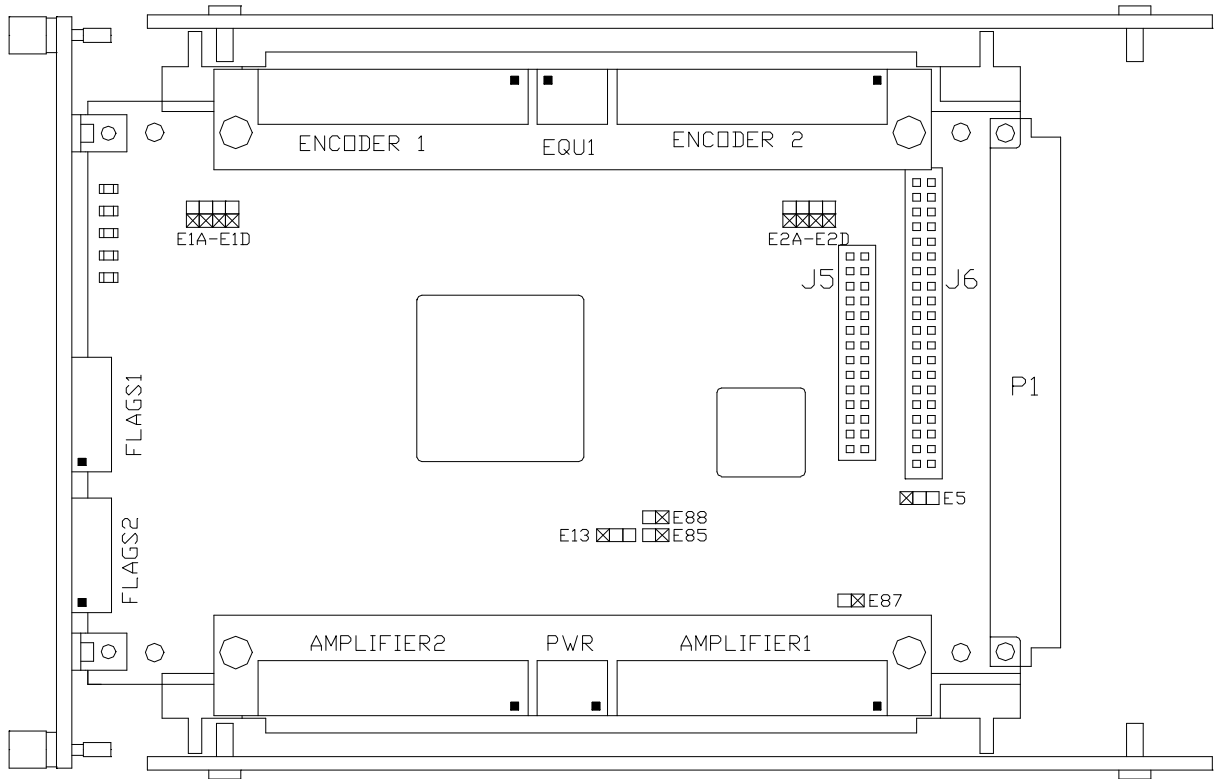

- Designates pin 1



## E-POINT JUMPER SETTINGS

### ACC-24E2A Base Board (Channels\* 1 & 2)

Jumper	Config.	Description	Default
E1A	1-2	No Jumper for TTL Level input for CHU1 flag Jumper 1-2 for DIR1+ output in Stepper Mode	No jumper
E1B	1-2	No Jumper for TTL Level input for CHV1 flag Jumper 1-2 for DIR1- output in Stepper Mode	No jumper
E1C	1-2	No Jumper for TTL Level input for CHW1 flag Jumper 1-2 for PUL1+ output in Stepper Mode	No jumper
E1D	1-2	No Jumper for TTL Level input for CHT1 flag Jumper 1-2 for PUL1- output in Stepper Mode	No jumper
E2A	1-2	No Jumper for TTL Level input for CHU2 flag Jumper 1-2 for DIR2+ output in Stepper Mode	No jumper
E2B	1-2	No Jumper for TTL Level input for CHV2 flag Jumper 1-2 for DIR2- output in Stepper Mode	No jumper
E2C	1-2	No Jumper for TTL Level input for CHW2 flag Jumper 1-2 for PUL2+ output in Stepper Mode	No jumper
E2D	1-2	No Jumper for TTL Level input for CHT2 flag Jumper 1-2 for PUL2- output in Stepper Mode	No jumper
E5	1-2-3	Jump 1-2 for Turbo 3U CPU and MACRO CPU ** Jump 2-3 for legacy MACRO CPU (before 6/00)	Jump 1-2
E13	1-2-3	Jump 1-2 to receive phase and servo clocks Jump 2-3 to transmit phase and servo clocks	Jump 1-2
E85	1-2	Jump 1-2 for Backplane Supplied +15V No Jumper for External Supplied +15V	Jump 1-2
E87	1-2	Jump 1-2 for Backplane Supplied AGND No Jumper for External Supplied AGND	Jump 1-2
E88	1-2	Jump 1-2 for Backplane Supplied -15V No Jumper for External Supplied -15V	Jump 1-2
OPT1	1-2	For factory use only	
OPT2	1-2	For factory use only	
<p>* The channels refer to the Servo IC associated with the ACC-24E2 base board. For example, an eight-axis application would have two ACC-24E2s with option 1. The first ACC-24E2 would have axes 1-4 and the second ACC-24E2 would contain axes 5-8.</p> <p>** for legacy MACRO Stations (part number 602804-100 thru 602804-104)</p>			

## ACC-24E2A Option 1 Board (Channels 3 & 4)

Jumper	Config.	Description	Default
E1A	1-2	No Jumper for TTL Level input for CHU3 flag Jumper 1-2 for DIR3+ output in Stepper Mode	No jumper
E1B	1-2	No Jumper for TTL Level input for CHV3 flag Jumper 1-2 for DIR3- output in Stepper Mode	No jumper
E1C	1-2	No Jumper for TTL Level input for CHW3 flag Jumper 1-2 for PUL3+ output in Stepper Mode	No jumper
E1D	1-2	No Jumper for TTL Level input for CHT3 flag Jumper 1-2 for PUL3- output in Stepper Mode	No jumper
E2A	1-2	No Jumper for TTL Level input for CHU4 flag Jumper 1-2 for DIR4+ output in Stepper Mode	No jumper
E2B	1-2	No Jumper for TTL Level input for CHV4 flag Jumper 1-2 for DIR4- output in Stepper Mode	No jumper
E2C	1-2	No Jumper for TTL Level input for CHW4 flag Jumper 1-2 for PUL4+ output in Stepper Mode	No jumper
E2D	1-2	No Jumper for TTL Level input for CHT4 flag Jumper 1-2 for PUL4- output in Stepper Mode	No jumper
E85	1-2	Jump 1-2 for Backplane Supplied +15V No Jumper for External Supplied +15V	Jump 1-2
E87	1-2	Jump 1-2 for Backplane Supplied AGND No Jumper for External Supplied AGND	Jump 1-2
E88	1-2	Jump 1-2 for Backplane Supplied -15V No Jumper for External Supplied -15V	Jump 1-2

## HARDWARE SETUP

---

### Position Compare Port Driver IC

---

As with the other PMAC controllers, the UMAC has the high speed position compare outputs allowing the user to fire an output based on position. This circuit will fire within 100 nsec of reaching the desired position. The position compare output port on the ACC-24E2 and its Option 1 daughter card have a socketed driver IC in a 8-pin DIP socket at component U27. This IC gives the user a fast CMOS driver.

The following table lists the properties of each driver IC:

Part	# of Pins	Max Voltage & Current	Output Type	Max Frequency	E11, E12 Setting
DS75451N	8	5V, 10 mA	Totem-Pole (CMOS)	5 MHz	1-2

### Switch Configuration

---

#### UMAC Address DIP Switch S1

S1, S1-3, S1-4 are used to address the ACC-24E2 as shown in the table below.

S1-1	S1-3	S1-4	Board No.	IC No.	I-Var. Range	Base Address
ON	ON	ON	1	2	I7200	\$078200
OFF	ON	ON	2	3	I7300	\$078300
ON	OFF	ON	3	4	I7400	\$079200
OFF	OFF	ON	4	5	I7500	\$079300
ON	ON	OFF	5	6	I7600	\$07A200
OFF	ON	OFF	6	7	I7700	\$07A300
ON	OFF	OFF	7	8	I7800	\$07B200
OFF	OFF	OFF	8	9	I7900	\$07B300

S1-2, S1-5, and S1-6 are used to determine whether or not the ACC-24E2 is communicating to a Turbo 3U PMAC or a MACRO Station CPU.

S1-2	S1-5	S1-6	Function
ON	ON	ON	3U Turbo PMAC Use

## MACRO Station Address DIP Switch S1

S1-1, S1-2, S1-3, S1-4 are used to address the ACC-24E2 as shown in the table below.

S1-1	S1-2*	S1-3	S1-4	Board No.	IC No.	Base Address
ON	ON	OFF	OFF	1	2	\$00C040
OFF	OFF	OFF	OFF	2	3	\$00C060

\* always set to off for legacy MACRO Stations (part number 602804-100 thru 602804-104)

S1-5, and S1-6 are used to determine whether or not the ACC-24E2 is communicating to a Turbo 3U PMAC or a MACRO Station CPU.

S1-5	S1-6	Function
OFF	OFF	3U MACRO Station use

## Resistor Pack Configuration

### Termination Resistors

The ACC-24E2A provides sockets for termination resistors on differential input pairs coming into the board. As shipped, there are no resistor packs in these sockets. If these signals are brought long distances into the ACC-24E2A board and ringing at signal transitions is a problem, SIP resistor packs may be mounted in these sockets to reduce or eliminate the ringing.

All termination resistor packs are the type that have independent resistors (no common connection) with each resistor using two adjacent pins.

### Channel Specific Resistor Packs

Channel 1	Channel 2	SIP	Description
RP22	RP24	2.2K $\Omega$	Reverse resistor pack for encoder loss feature (for differential encoders only)
RP23	RP25	220 $\Omega$	Termination resistor to reduce ringing (not installed by default).
RP45	RP46	1K $\Omega$	Install for 5V limits

### UBUS Specific Resistor Packs

Resistor Pack	SIP	Description
RP5	220 $\Omega$	Terminator (not installed, only used for non-UBUS)
RP6	2.2K $\Omega$	Pull Down for Old MACRO CPU Pull Up for UMAC Turbo & MACRO

## ACC-24E2 Limit and Flag Wiring

The ACC-24E2 allows the user to use sinking or sourcing position limits and flags to the controller. The optoisolator IC used is a PS2705-4NEC-ND quad photo-transistor output type. This IC allows the current to flow from return to flag (sinking) or from flag to return (sourcing).

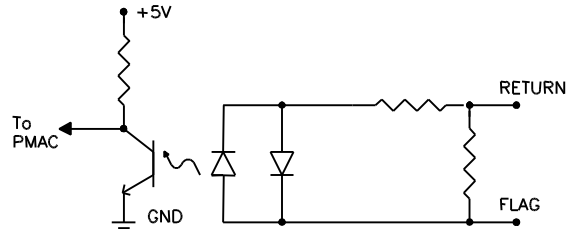

### ACC-24E2 Limit/Flag Circuit

A sample of the positive limit circuit is shown below. The 4.7K resistor packs used will allow 12-24V flag inputs. If 0-5 voltage flags are used, then a 1K $\Omega$  resistor pack (RP) can be placed in either RP45 or RP46 (please refer to the Resistor Pack description section of this manual). If the user does add these resistor packs, all flags ( $\pm$ Limits, Home, User, and amplifier fault) will be referenced from 0-5V.

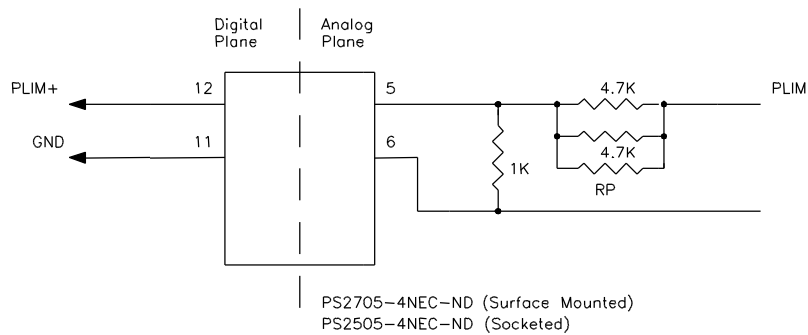

## Connecting Limits/Flags to the ACC-24E2

The following diagrams illustrate the sinking and sourcing connections to an ACC-24E2. For this example we are assuming the use of 12-24V flags.

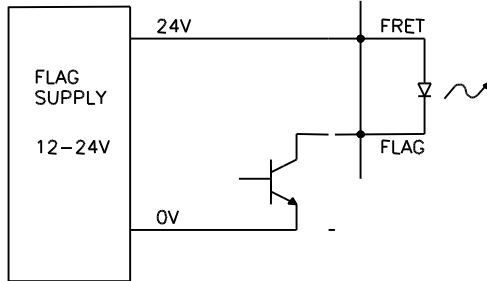

**Sinking,  
Separate  
Supply**

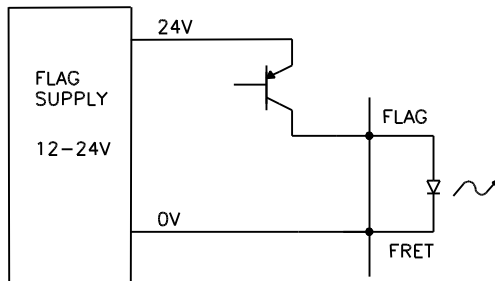

**Sourcing,  
Separate  
Supply**

## Amplifier Fault Circuit

The amplifier fault circuit for the ACC-24E2A is functionally the same circuit as the limits and flag circuit.

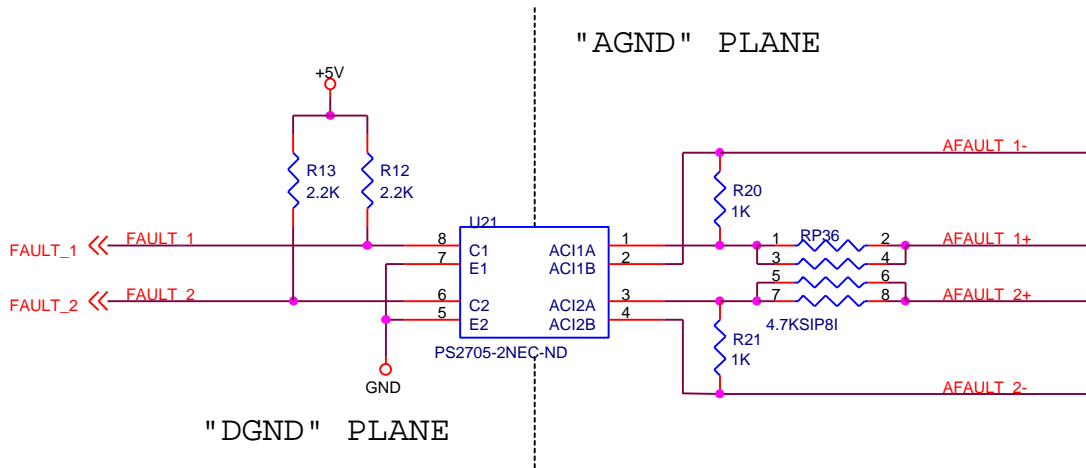

For single ended amplifier fault inputs, the AFAULT+ would typically be the actual signal input from the amplifier and the AFAULT- can be considered the reference.

### Single Ended Amplifier Fault Inputs

AFAULT+	AFAULT-	INPUT TYPE
0V	+12V to 24V	Sinking – Low True
12V to 24V	0V	Sourcing – High True

## Loss of Encoder Circuit

Delta Tau has created a circuit to detect encoder loss. **The circuit was designed to work with differential TTL level encoders only (A, A/, B, B/, C, C/).** The circuit design is in the ACC-1E, ACC-2E, and ACC-24E2 accessories for the UMAC and MACRO products and has been implemented in the new design for the Mini PMAC2, and Universal PMAC2-Lite.

In order to enable this function, the socketed resistor packs for the encoder must be reversed from their factory default setting so that the complementary encoder lines A/, B/, and C/ are pulled up to 5V instead of pulled to 2.5V. The resistor packs to be reversed are RP22, RP24,

ACC-24E2	ACC-24E2 Option 1
RP22 – Channel1	RP22 – Channel3
RP24 – Channel2	RP24 – Channel4

## **ACC-24E2 Clock Settings**

---

The Phase Clock and Servo Clock must be configured on each ACC-24E2 base board. Each system can have only one source for the servo and phase clocks and jumpers must be set appropriately to avoid a timing conflict and a watchdog condition.

For MACRO, set jumper E13 to receive servo and phase clocks.

For UMAC-Turbo, set one of the ACC-24E2's to transmit the phase and servo clock and the rest of the ACC-24E2s to receive the phase and servo clock.

## UMAC SOFTWARE SETUP

---

---

### System Configuration I-Variables

---

Starting in Turbo PMAC firmware version V1.934, the Turbo PMAC automatically determines which Servo and MACRO ICs are present on power-up/reset and enables the I-variables for these ICs.

In previous versions, the user had to set I65 manually to tell the Turbo PMAC which ICs were present, so the proper I-variables could be enabled. In V1.934 and newer versions, Turbo PMAC reports which ICs are present in read-only variable I4900. If using an Turbo PMAC with firmware 1.933 and below, please refer to the Turbo PMAC Software Reference Manual for a detailed description of these system configuration I-variables.

### Servo IC Configuration I-Variables

---

Turbo PMAC I-variables in the range I7000 – I7999 control the configuration of the Servo ICs. The hundred's digit represents the number of the Servo IC (0 to 9) in the system. Servo ICs 0 and 1 are (or can be) on board the Turbo PMAC board itself. Servo ICs 2 through 9 are (or can be) on external devices such as the ACC-24E2.

#### Servo IC Numbering

The number 'm' of the Servo IC on the ACC-24E2 board is dependent on the addressing of the board with DIP switches S1-1, S1-3, and S1-4, which place the board as the 1<sup>st</sup> through 8<sup>th</sup> external device:

- 1<sup>st</sup> ACC-24E2 with option 1: Servo IC 2 (channels 1-4)
- 2<sup>nd</sup> ACC-24E2 with option 1 Servo IC 3 (channels 5-8)
- 3<sup>rd</sup> ACC-24E2 with option 1: Servo IC 4 (channels 9-12)
- 4<sup>th</sup> ACC-24E2 with option 1 Servo IC 5 (channels 13-16)
- 5<sup>th</sup> ACC-24E2 with option 1: Servo IC 6 (channels 17-20)
- 6<sup>th</sup> ACC-24E2 with option 1 Servo IC 7 (channels 21-24)
- 7<sup>th</sup> ACC-24E2 with option 1: Servo IC 8 (channels 25-28)
- 8<sup>th</sup> ACC-24E2 with option 1 Servo IC 9 (channels 29-32)

The “Standard” Servo IC on an ACC-24E2 occupies Channels 1 – 2 on the board, using connectors associated with channels 1 and 2. The “Option 1” on an ACC-24E2 occupies Channels 3 – 4 on the board, using connectors associated with channels 3 and 4.

For example, the “Standard” Servo IC on the 1<sup>st</sup> ACC-24E2 is Servo IC 2 to Turbo PMAC and is configured by variables I7200 – I7299.

## Servo Channel Numbering

Each Servo IC has 4 channels of servo interface circuitry. The ten's digit 'n' of the I-variable configuring the IC represents the channel number on the IC (n = 1 to 4). For example, Channel 1 of the "Standard" Servo IC on the 1<sup>st</sup> ACC-24E2 is configured by variables I7210 – I7219. These channel-specific I-variables are represented generically as I7mn0 – I7mn9, where 'm' represents the Servo IC number (0 – 9) and 'n' represents the IC channel number (1 – 4).

The Channels 1 – 4 on the "Standard" Servo IC of an ACC-24E2 correspond to Channels 1 – 4, respectively, on the ACC-24E2 board itself.

I-variables in the I7000s for which the ten's digit is '0' ("Channel 0") affect all 4 channels of the PMAC2-style Servo IC on the ACC-24E2. These multi-channel I-variables are represented generically as I7m00 – I7m09.

## Multi-Channel I-Variables

There are several multi-channel I-variables that must be set up properly for proper operation of the ACC-24E2 in a Turbo PMAC system. The most important are:

- **I7m07: Servo IC m Phase/Servo Clock Direction:** This variable should be set to 3 for any Servo IC on an ACC-24E2 so it inputs its phase and servo clocks from signals generated on the Turbo PMAC itself.
- **I7m00: Servo IC m MaxPhase/PWM Frequency Control:** Typically this will be set to the same value as the variable that controls the system clocks: I7000 on a non-Ultralite Turbo PMAC2, or I6800 on a Turbo PMAC2 Ultralite. If a different PWM frequency is desired, or the ACC-24E2 is used with a Turbo PMAC(1) in which the system clock frequencies are set by jumpers, then the following constraint should be observed in setting this variable:

$$\frac{2 * PWMFreq(kHz)}{PhaseFreq} = \{Integer\}$$

- **I7m01: Servo IC m Phase Clock Frequency Control:** Even though the IC is receiving an external phase clock (see I7m07, above), it is usually best to create the same internal phase clock frequency in the Servo IC. This yields the following constraint:

$$\begin{aligned} I7m00 * (I7m01 + 1) &= I7000 * (I7001 + 1) && \{non-Ultralite Turbo PMAC2\} \\ I7m00 * (I7m01 + 1) &= I6800 * (I6801 + 1) && \{Turbo PMAC2 Ultralite\} \end{aligned}$$

Solving for I7m01, we get

$$\begin{aligned} I7m01 &= \frac{I7000 * (I7001 + 1)}{I7m00} - 1 && \{non Ultralite PMAC2\} \\ I7m01 &= \frac{I6800 * (I6801 + 1)}{I7m00} - 1 && \{Turbo PMAC2 Ultralite\} \end{aligned}$$

If I7m00 is the same as I7000 or I6800, I7m01 will be the same as I7001 or I6801. If the ACC-24E2 is interfaced to a Turbo PMAC(1) board, it should be set by calculation to obtain the same phase clock frequency as that set by the jumpers on the Turbo PMAC(1).

- **I7m02: Servo IC m Servo Clock Frequency Control:** Even though the IC is receiving an external servo clock (see I7m07, above), it is usually best to create the same internal servo clock frequency in the Servo IC. This means that I7m02 for the IC should be set the same as I7002 on a non-Ultralite Turbo PMAC2, or the same as I6802 on a Turbo PMAC2 Ultralite. When connected to a Turbo PMAC(1), I7m02 should create the same division from the phase clock as jumpers E3 – E6 do on the Turbo PMAC(1).
- **I7m03: Servo IC m Hardware Clock Frequency Control:** The hardware clock frequencies for the Servo IC should be set according to the devices attached to it. There is no reason for these frequencies to be the same between ICs. There is seldom a reason to change this value from the default.

### Single-Channel I-Variables

The single-channel setup I-variables for Channel ‘n’ of Servo IC ‘m’ work exactly the same on an ACC-24E2 as they do on a Turbo PMAC2 itself. Each Servo IC has 4 channels ‘n’, numbered 1 to 4. For the first (standard) Servo IC on the ACC-24E2, the channel numbers 1 – 4 on the Servo IC are the same as the channel numbers 1 – 4 on the board. The most important variables are:

- **I7mn0: Servo IC m Channel n Encoder Decode Control:** Typically, I7mn0 is set to 3 or 7 for “x4” quadrature decode, depending on which way is “up.” If the channel is used for open-loop stepper drive, I7mn0 is set to 8 to accept internal pulse-and-direction, or to 0 to accept external pulse-and-direction (e.g. from an ACC-8S). It is set to 12 if the channel is used for MLDT feedback.
- **I7mn2: Servo IC m Channel n Capture Control:** I7mn2 determines whether the encoder index channel, an input flag, or both, are used for the capture of the encoder position.
- **I7mn3: Servo IC m Channel n Capture Flag Select:** I7mn3 determines which input flag is used for encoder capture, if one is used.
- **I7mn6: Servo IC m Channel n Output Mode Select:** I7mn6 determines whether the A and B outputs are DAC or PWM, and whether the C output is PFM (pulse-and-direction) or PWM. Typically, it is set either to 0, for 3-phase PWM, or to 3 for DACs and PFM.

### Encoder Conversion Table I-Variables

To use feedback or master position data from an ACC-24E2, you must add entries to the encoder conversion table (ECT) using I-variables I8000 – I8191 to address and process this data. The default conversion table in the Turbo PMAC does not contain these entries; it only contains entries for the 8 channels on board the Turbo PMAC.

Usually, the position data obtained through an ACC-24E2 board is an incremental encoder feedback, and occasionally an A/D converter feedback from an ACC-28B board connected through the ACC-24E2.

The ECT entries for ACC-24E2 incremental encoder channels are shown in the following table:

Encoder Channel #	1 <sup>st</sup> & 2 <sup>nd</sup> ACC-24E2	3 <sup>rd</sup> & 4 <sup>th</sup> ACC-24E2	5 <sup>th</sup> and 6 <sup>th</sup> ACC-24E2	7 <sup>th</sup> and 8 <sup>th</sup> ACC-24E2
Channel 1	\$mF8200	\$mF9200	\$mFA200	\$mFB200
Channel 2	\$mF8208	\$mF9208	\$mFA208	\$mFB208
Channel 3	\$mF8210	\$mF9210	\$mFA210	\$mFB210
Channel 4	\$mF8218	\$mF9218	\$mFA218	\$mFB218
Channel 5	\$mF8300	\$mF9300	\$mFA300	\$mFB300
Channel 6	\$mF8308	\$mF9308	\$mFA308	\$mFB308
Channel 7	\$mF8310	\$mF9310	\$mFA310	\$mFB310
Channel 8	\$mF8318	\$mF9318	\$mFA318	\$mFB318

The first hexadecimal digit in the entry, represented by ‘m’ in the table, is a ‘0’ for the most common 1/T timer-based extension of digital incremental encoders; it is an ‘8’ for the parallel-data extension of analog incremental encoders; it is a ‘C’ for no extension of an incremental encoder.

### Motor Addressing I-Variables

For a Turbo PMAC motor to use the servo interface circuitry of the ACC-24E2, several of the addressing I-variables for the motor must contain the addresses of registers in the ACC-24E2, or the addresses of encoder conversion table registers containing data processed from the ACC-24E2. These I-variables can include:

- **Ixx02: Motor xx Command Output Address:** Ixx02 tells Turbo PMAC where to write its command outputs for Motor xx. If ACC-24E2 is to create the command signals, Ixx02 must contain the address of the register.

The following table shows the address of the ‘A’ output register for each channel of each ACC-24E2. These addresses can be used for single analog outputs, double analog outputs, or direct PWM outputs.

ACC-24E2 Register: Board No. & Channel	Address / Ixx02 Value	UMAC- Turbo	ACC-24E2 Register: Board No. & Channel	Address / Ixx02 Value	UMAC- Turbo
1 <sup>st</sup> ACC-24E/V2 DAC/PWM1A	\$078202	I102	3 <sup>rd</sup> ACC-24E/V2 DAC/PWM1A	\$07A202	I1702
1 <sup>st</sup> ACC-24E/V2 DAC/PWM2A	\$07820A	I202	3 <sup>rd</sup> ACC-24E/V2 DAC/PWM2A	\$07A20A	I1802
1 <sup>st</sup> ACC-24E/V2 DAC/PWM3A	\$078212	I302	3 <sup>rd</sup> ACC-24E/V2 DAC/PWM3A	\$07A212	I1902
1 <sup>st</sup> ACC-24E/V2 DAC/PWM4A	\$07821A	I402	3 <sup>rd</sup> ACC-24E/V2 DAC/PWM4A	\$07A21A	I2002
1 <sup>st</sup> ACC-24E/V2 DAC/PWM5A	\$078302	I502	3 <sup>rd</sup> ACC-24E/V2 DAC/PWM5A	\$07A302	I2102
1 <sup>st</sup> ACC-24E/V2 DAC/PWM6A	\$07830A	I602	3 <sup>rd</sup> ACC-24E/V2 DAC/PWM6A	\$07A30A	I2202
1 <sup>st</sup> ACC-24E/V2 DAC/PWM7A	\$078312	I702	3 <sup>rd</sup> ACC-24E/V2 DAC/PWM7A	\$07A312	I2302
1 <sup>st</sup> ACC-24E/V2 DAC/PWM8A	\$07831A	I802	3 <sup>rd</sup> ACC-24E/V2 DAC/PWM8A	\$07A31A	I2402
2 <sup>nd</sup> ACC-24E/V2 DAC/PWM1A	\$079202	I902	4 <sup>th</sup> ACC-24E/V2 DAC/PWM1A	\$07B202	I2502
2 <sup>nd</sup> ACC-24E/V2 DAC/PWM2A	\$07920A	I1002	4 <sup>th</sup> ACC-24E/V2 DAC/PWM2A	\$07B20A	I2602
2 <sup>nd</sup> ACC-24E/V2 DAC/PWM3A	\$079212	I1102	4 <sup>th</sup> ACC-24E/V2 DAC/PWM3A	\$07B212	I2702
2 <sup>nd</sup> ACC-24E/V2 DAC/PWM4A	\$07921A	I1202	4 <sup>th</sup> ACC-24E/V2 DAC/PWM4A	\$07B21A	I2802
2 <sup>nd</sup> ACC-24E/V2 DAC/PWM5A	\$079302	I1302	4 <sup>th</sup> ACC-24E/V2 DAC/PWM5A	\$07B302	I2902
2 <sup>nd</sup> ACC-24E/V2 DAC/PWM6A	\$07930A	I1402	4 <sup>th</sup> ACC-24E/V2 DAC/PWM6A	\$07B30A	I3002
2 <sup>nd</sup> ACC-24E/V2 DAC/PWM7A	\$079312	I1502	4 <sup>th</sup> ACC-24E/V2 DAC/PWM7A	\$07B312	I3102
2 <sup>nd</sup> ACC-24E/V2 DAC/PWM8A	\$07931A	I1602	4 <sup>th</sup> ACC-24E/V2 DAC/PWM8A	\$07B31A	I3202

If the ‘C’ output register for a given ACC-24E2 and channel is used (primarily for pulse and direction output), simply add 2 to the address shown in the above table. For example, on the first ACC-24E2, output register 1C is at address \$078204.

**Ixx03: Motor xx Position-Loop Feedback Address**

**Ixx04: Motor xx Velocity-Loop Feedback Address**

**Ixx05: Motor xx Master Position Address**

The Ixx03, Ixx04, and Ixx05 variables almost always contain the address of a processed position value in the encoder conversion table, even when the raw data comes from the ACC-24E2. The first line of the encoder conversion table is at address \$003501; the last line is at address \$0035C0.

**Ixx10: Motor xx Power-On Position Address:** Ixx10 tells the Turbo PMAC where to read absolute power-on position, if any. Typically, the only times Ixx10 will contain the address of an ACC-24E2 register is if the position is obtained from an A/D converter on an ACC-28B connected through the ACC-24E2, or if it is obtained from an MLDT (e.g. Temposonics™) sensor excited directly from an ACC-24E2.

The following table shows the possible values of Ixx10 for MLDT timer registers:

**Ixx10 for ACC-24E2 MLDT Timer Registers (Ixx95=\$170000)**

MLDT Timer Channel #	1 <sup>st</sup> & 2 <sup>nd</sup> ACC-24E2	3 <sup>rd</sup> & 4 <sup>th</sup> ACC-24E2	5 <sup>th</sup> & 6 <sup>th</sup> ACC-24E2	7 <sup>th</sup> & 8 <sup>th</sup> ACC-24E2
Channel 1	\$078200	\$079200	\$07A200	\$07B200
Channel 2	\$078208	\$079208	\$07A208	\$07B208
Channel 3	\$078210	\$079210	\$07A210	\$07B210
Channel 4	\$078218	\$079218	\$07A218	\$07B218
Channel 5	\$078300	\$079300	\$07A300	\$07B300
Channel 6	\$078308	\$079308	\$07A308	\$07B308
Channel 7	\$078310	\$079310	\$07A310	\$07B310
Channel 8	\$078318	\$079318	\$07A318	\$07B318

- Ixx24: Motor xx Flag Mode:** Ixx24 defines how to read and use the flags for Motor xx that are in the register specified by Ixx25. Ixx24 is a set of independent control bits. There are two bits that must be set correctly to use a flag set on an ACC-24E2.

Bit 0 of Ixx24 must be set to 1 to tell the Turbo PMAC that this flag set is in a “Type 1” PMAC2-style Servo IC. Bit 18 of Ixx24 must be set to 0 to tell the Turbo PMAC that this flag set is *not* transmitted over a MACRO ring. Other bits of Ixx24 may be set as desired for a particular application.
- Ixx25: Motor xx Flag Address:** Ixx25 tells Turbo PMAC where to access its flag data for Motor xx. If ACC-24E2 is interfaced to the flags, Ixx25 must contain the address of the flag register in ACC-24E2. The following table shows the address of the flag register for each channel of each ACC-24E2.

ACC-24E2 Register: Board No. & Channel	Address / Ixx25 Value	UMAC Default for:	ACC-24E2 Register: Board No. & Channel	Address / Ixx25 Value	UMAC Default for:
1 <sup>st</sup> ACC-24E/V2 Flag Set 1	\$078200	I125	3 <sup>rd</sup> ACC-24E/V2 Flag Set 1	\$07A200	I1725
1 <sup>st</sup> ACC-24E/V2 Flag Set 2	\$078208	I225	3 <sup>rd</sup> ACC-24E/V2 Flag Set 2	\$07A208	I1825
1 <sup>st</sup> ACC-24E/V2 Flag Set 3	\$078210	I325	3 <sup>rd</sup> ACC-24E/V2 Flag Set 3	\$07A210	I1925
1 <sup>st</sup> ACC-24E/V2 Flag Set 4	\$078218	I425	3 <sup>rd</sup> ACC-24E/V2 Flag Set 4	\$07A218	I2025
1 <sup>st</sup> ACC-24E/V2 Flag Set 5	\$078300	I525	3 <sup>rd</sup> ACC-24E/V2 Flag Set 5	\$07A300	I2125
1 <sup>st</sup> ACC-24E/V2 Flag Set 6	\$078308	I625	3 <sup>rd</sup> ACC-24E/V2 Flag Set 6	\$07A308	I2225
1 <sup>st</sup> ACC-24E/V2 Flag Set 7	\$078310	I725	3 <sup>rd</sup> ACC-24E/V2 Flag Set 7	\$07A310	I2325
1 <sup>st</sup> ACC-24E/V2 Flag Set 8	\$078318	I825	3 <sup>rd</sup> ACC-24E/V2 Flag Set 8	\$07A318	I2425
2 <sup>nd</sup> ACC-24E/V2 Flag Set 1	\$079200	I925	4 <sup>th</sup> ACC-24E/V2 Flag Set 1	\$07B200	I2525
2 <sup>nd</sup> ACC-24E/V2 Flag Set 2	\$079208	I1025	4 <sup>th</sup> ACC-24E/V2 Flag Set 2	\$07B208	I2625
2 <sup>nd</sup> ACC-24E/V2 Flag Set 3	\$079210	I1125	4 <sup>th</sup> ACC-24E/V2 Flag Set 3	\$07B210	I2725
2 <sup>nd</sup> ACC-24E/V2 Flag Set 4	\$079218	I1225	4 <sup>th</sup> ACC-24E/V2 Flag Set 4	\$07B218	I2825
2 <sup>nd</sup> ACC-24E/V2 Flag Set 5	\$079300	I1325	4 <sup>th</sup> ACC-24E/V2 Flag Set 5	\$07B300	I2925
2 <sup>nd</sup> ACC-24E/V2 Flag Set 6	\$079308	I1425	4 <sup>th</sup> ACC-24E/V2 Flag Set 6	\$07B308	I3025
2 <sup>nd</sup> ACC-24E/V2 Flag Set 7	\$079310	I1525	4 <sup>th</sup> ACC-24E/V2 Flag Set 7	\$07B310	I3125
2 <sup>nd</sup> ACC-24E/V2 Flag Set 8	\$079318	I1625	4 <sup>th</sup> ACC-24E/V2 Flag Set 8	\$07B318	I3225

- **Ixx81: Motor xx Power-On Phase Position Address:** Ixx81 tells Turbo PMAC2 where to read absolute power-on position for motor phase commutation, if any. Typically, it will contain the address of an ACC-24E2 register for only two types of absolute phasing sensors: hall-effect commutation sensors (or their optical equivalents) connected to the U, V, and W input flags on an ACC-24E2 channel, or the encoder counter filled by simulated quadrature from a Yaskawa absolute encoder connected to the ACC-24E2 through an ACC-8D Option 9 board.

The following table contains the possible settings of Ixx81 for hall sensor absolute position with an ACC-24E2:

**Turbo PMAC Ixx81 ACC-24E2 Hall Phasing Settings**

(Ix91=\$800000 - \$FF0000)

Hall Flag Channel #	1 <sup>st</sup> & 2 <sup>nd</sup> ACC-24E2	3 <sup>rd</sup> & 4 <sup>th</sup> ACC-24E2	5 <sup>th</sup> & 6 <sup>th</sup> ACC-24E2	7 <sup>th</sup> & 8 <sup>th</sup> ACC- 24E2
Channel 1	\$078200	\$079200	\$07A200	\$07B200
Channel 2	\$078208	\$079208	\$07A208	\$07B208
Channel 3	\$078210	\$079210	\$07A210	\$07B210
Channel 4	\$078218	\$079218	\$07A218	\$07B218
Channel 5	\$078300	\$079300	\$07A300	\$07B300
Channel 6	\$078308	\$079308	\$07A308	\$07B308
Channel 7	\$078310	\$079310	\$07A310	\$07B310
Channel 8	\$078318	\$079318	\$07A318	\$07B318

The following table contains the possible settings of Ixx81 to read the encoder counters for Yaskawa absolute encoders:

**Turbo PMAC Ixx81 ACC-24E2 Encoder Register Settings**

(Ix91=\$480000 - \$580000)

Encoder Register Channel #	1 <sup>st</sup> & 2 <sup>nd</sup> ACC-24E2	3 <sup>rd</sup> & 4 <sup>th</sup> ACC-24E2	5 <sup>th</sup> & 6 <sup>th</sup> ACC-24E2	7 <sup>th</sup> & 8 <sup>th</sup> ACC-24E2
Channel 1	\$078201	\$079201	\$07A201	\$07B201
Channel 2	\$078209	\$079209	\$07A209	\$07B209
Channel 3	\$078211	\$079211	\$07A211	\$07B211
Channel 4	\$078219	\$079219	\$07A219	\$07B219
Channel 5	\$078301	\$079301	\$07A301	\$07B301
Channel 6	\$078309	\$079309	\$07A309	\$07B309
Channel 7	\$078311	\$079311	\$07A311	\$07B311
Channel 8	\$078319	\$079319	\$07A319	\$07B319

- **Ixx82: Motor xx Current Feedback Address:** Ixx82 tells Turbo PMAC where to get its current-loop feedback every phase update cycle. If Ixx82 is set to 0, Turbo PMAC does not perform current-loop calculations for Motor xx.

The following table shows the possible values of Ixx82 for ACC-24E2 ADC register pairs:

**Turbo PMAC Ixx82 ACC-24E2 ADC Register Settings**

ADC Register Channel #	1 <sup>st</sup> & 2 <sup>nd</sup> ACC-24E2	3 <sup>rd</sup> & 4 <sup>th</sup> ACC-24E2	5 <sup>th</sup> & 6 <sup>th</sup> ACC-24E2	7 <sup>th</sup> & 8 <sup>th</sup> ACC-24E2
Channel 1	\$078206	\$079206	\$07A206	\$07B206
Channel 2	\$07820E	\$07920E	\$07A20E	\$07B20E
Channel 3	\$078216	\$079216	\$07A216	\$07B216
Channel 4	\$07821E	\$07921E	\$07A21E	\$07B21E
Channel 5	\$078306	\$079306	\$07A306	\$07B306
Channel 6	\$07830E	\$07930E	\$07A30E	\$07B30E
Channel 7	\$078316	\$079316	\$07A316	\$07B316
Channel 8	\$07831E	\$07931E	\$07A31E	\$07B31E

- **Ixx83: Motor xx Phase Position Address:** Ixx83 tells Turbo PMAC where to get its commutation position feedback every phase update cycle. This almost always contains the address of an encoder “phase position” register.

The following table shows the possible values of Ixx83 for ACC-24E2 encoder phase position registers:

### Turbo PMAC Ixx83 ACC-24E2 Encoder Register Settings

Encoder Register Channel #	1 <sup>st</sup> & 2 <sup>nd</sup> ACC-24E2	3 <sup>rd</sup> & 4 <sup>th</sup> ACC-24E2	5 <sup>th</sup> & 6 <sup>th</sup> ACC-24E2	7 <sup>th</sup> & 8 <sup>th</sup> ACC-24E2
Channel 1	\$078201	\$079201	\$07A201	\$07B201
Channel 2	\$078209	\$079209	\$07A209	\$07B209
Channel 3	\$078211	\$079211	\$07A211	\$07B211
Channel 4	\$078219	\$079219	\$07A219	\$07B219
Channel 5	\$078301	\$079301	\$07A301	\$07B301
Channel 6	\$078309	\$079309	\$07A309	\$07B309
Channel 7	\$078311	\$079311	\$07A311	\$07B311
Channel 8	\$078319	\$079319	\$07A319	\$07B319

### UMAC Turbo Example Setups

---

The following section will show the user how to quickly setup the key variables for a DAC output system and for a combination torque mode (DAC) and stepper sotor (PFM) system.

For these examples, the factory defaults for the other variables will allow the user to command DAC outputs and FM outputs with a low true Amplifier Fault and  $\pm$ Limits plugged in. If this is not the case then Ixx24 will have to be modified. The PID gains will also have to be modified for optimum closed loop control

**Example A: 4 axis DAC outputs from base address \$078200 (servo IC2)**

For this type of system, the user will have to make sure I7mn6 is set for DAC output mode. Remember, UMAC Turbo has three outputs per channel (CHnA, CHnB, and CHnC)

I7216=3 ;CH1A and CH1B ouputs will be DAC and CH1C output will be PFM  
 I7226=3 ;CH2A and CH2B ouputs will be DAC and CH2C output will be PFM  
 I7236=3 ;CH3A and CH3B ouputs will be DAC and CH3C output will be PFM  
 I7246=3 ;CH4A and CH4B ouputs will be DAC and CH4C output will be PFM

**Example B: 2 axis PFM outputs and 2 axes PFM from base address \$078200 (servo IC2). Assume DAC outputs on channels 1 and 2 and PFM outputs on channels 3 & 4. Jumpers E1A through E2D must be jumpered on ACC-24E2A option 1 only.**

For this type of system, the user will have to make sure I7mn6 is set for DAC and PFM output mode.

I7216=3 ;CH1A and CH1B ouputs will be DAC and CH1C output will be PFM  
 I7226=3 ;CH2A and CH2B ouputs will be DAC and CH2C output will be PFM  
 I7236=3 ;CH3A and CH3B ouputs will be DAC and CH3C output will be PFM  
 I7246=3 ;CH4A and CH4B ouputs will be DAC and CH4C output will be PFM

I102=\$078202 ;Command output to CH1A address (default) for DAC  
 I202=\$07820A ;Command output to CH2A address (default) for DAC  
 I302=\$078214 ;Command output to CH3C address (default address + 2) for Stepper  
 I402=\$07821C ;Command output to CH4C address (default address +2) for Stepper



## ULTRALITE/MACRO STATION SETUP

---

The ACC-24E2 family of JEXP accessories can also be used with MACRO Station to breakout the standard amplifier, flag, and encoder signals. The gate arrays on the ACC-24E2 family of accessories are located in the traditional channel 9-16 locations of the PMAC2 memory map. In order for the MACRO Station to set up its output and input channels automatically, the user must be using MACRO Station firmware 1.114 or greater. Currently there are 3 types of ACC-24E's to be used with the MACRO Station:

1. ACC-24E2 - Direct PWM commutation outputs
2. ACC-24E2A -  $\pm 10V$  Outputs for torque, velocity and sinusoidal input amplifiers
3. ACC-24E2S - Dedicated 4-channel stepper interface card

### MACRO Station Gate Array Locations for ACC-24E2

Chan #	9	10	11	12	13	14	15	16
Hex	[\$C040]	[\$C048]	[\$C050]	[\$C058]	[\$C060]	[\$C068]	[\$C070]	[\$C078]

## Hardware Setup for MACRO Station Use

---

There are a few hardware selections the user must set in order to use this accessory with the MACRO Station:

- E5 - Jumper 1-2 for MACRO/Turbo Communications
- E13 - Jumper 1-2 for Clock Settings
- SW1 - SW1-1 and SW1-2 ON for \$C040, SW1-1 and SW1-2 OFF for \$C060
- SW1 - SW1-3 through SW1-6 set to OFF

## Software Setup for MACRO Station Use

---

The user will have several choices when it comes to the software setup for the MACRO Station. At the MACRO Station the user must setup the ring frequency with MSn,MI992. The ACC-24E2A will have its MaxPhase Clock Frequency variables (MSn,MI900 and MSn,MI906) set to the same value as MSn,MI992 to ensure synchronous data exchange. The Delta Tau Setup software for either the standard PMAC2 Ultralite or Turbo PMAC2 Ultralite will set up all of these important MI-Variables at the MACRO Station.

The ACC-24E2A uses an 18-bit DAC and the DAC Strobe word (MSn,MI905 and MSn,MI909) must be setup for 18-bits to ensure proper operation of the DAC's. The released MACRO Station firmware version 1.14 will set the DAC strobe variables automatically. Pre-release versions of the 1.14 firmware must have the user manually set the DAC strobe word to \$7FFFC0 for proper 18-bit DAC operation.

MS{anynode},MI992 Ring Frequency Control  
 MS{anynode},MI900 - Channels 1-4 Frequency Control  
 MS{anynode},MI905 - DAC 1-4 Strobe Word  
 MS{anynode},MI906 - Channels 5-8 Frequency Control

MS{anynode},MI909 - DAC 5-8 Strobe Word

### Node-Specific Gate Array MI-variables

MI-variables MI910 through MI919 on the MACRO station control the hardware setup of the hardware interface channel on the station associated with a MACRO node. The matching of hardware interface channels to MACRO nodes is determined by the setting of the SW1 rotary switch on the CPU/Interface Board of the MACRO station.

These variables are accessed using the “MS” station auxiliary read and write commands. The number immediately after the “MS” specifies the node number, and therefore the channel number mapped to that node by the SW1 setting.

### Encoder/Timer n Decode Control (MSn, MI910)

MI910 controls how the input signal for the encoder mapped to the specified node is decoded into counts. As such, this defines the sign and magnitude of a "count." The following settings may be used to decode an input signal:

- 0: Pulse and direction CW
- 1: x1 quadrature decode CW
- 2: x2 quadrature decode CW
- 3: x4 quadrature decode CW
- 4: Pulse and direction CCW
- 5: x1 quadrature decode CCW
- 6: x2 quadrature decode CCW
- 7: x4 quadrature decode CCW
- 8: Internal pulse and direction
- 9: Not used
- 10: Not used
- 11: Not used
- 12: MLDT pulse timer control  
(internal pulse resets timer; external pulse latches timer)
- 13: Not used
- 14: Not used
- 15: Not used

In any of the quadrature decode modes, PMAC is expecting two input waveforms on CHAn and CHBn, each with approximately 50% duty cycle, and approximately one-quarter of a cycle out of phase with each other. "Times-one" (x1) decode provides one count per cycle; x2 provides two counts per cycle; and x4 provides four counts per cycle. The vast majority of users select x4 decode to get maximum resolution.

The "clockwise" (CW) and "counterclockwise" (CCW) options simply control which direction counts up. If you get the wrong direction sense, simply change to the other option (e.g. from 7 to 3 or vice versa).

---

**Warning:**

If you change the direction sense of an encoder with a properly working servo without also changing the direction sense of the output, you can get destabilizing positive feedback to your servo and a dangerous runaway condition.

---

In the pulse-and-direction decode modes, PMAC is expecting the pulse train on CHAn, and the direction (sign) signal on CHBn. If the signal is unidirectional, the CHBn line can be allowed to pull up to a high state, or it can be hardwired to a high or low state.

If MI910 is set to 8, the decoder inputs the pulse and direction signal generated by Channel n's pulse frequency modulator (PFM) output circuitry. This permits the Compact MACRO Station to create a phantom closed loop when driving an open-loop stepper system. *No jumpers or cables are needed to do this; the connection is entirely within the ASIC.* The counter polarity automatically matches the PFM output polarity.

If MI910 is set to 12, the timer circuitry is set up to read magnetostrictive linear displacement transducers (MLDTs) such as Temposonics™. In this mode, the timer is cleared when the PFM circuitry sends out the excitation pulse to the sensor on PULSEn, and it is latched into the memory-mapped register when the excitation pulse is received on CHAn.

### Flag Capture Control (MSn, MI911–MI913)

The flag capture registers must also be set up at the MACRO Station for proper homing, encoder capturing, and setting compare outputs.

**MI911** determines which encoder input the position compare circuitry for the machine interface channel mapped to the specified node uses.

MSn, MI911=0            Use channel n encoder counter for position compare function

MSn, MI911=1            Use first encoder counter on IC (encoder 1 for channels 1 to 4;  
encoder 5 for channels 5 to 8) for position compare function

When MI911 is set to 0, the channel's position compare register is tied to the channel's own encoder counter, and the position compare signal appears only on the EQU<sub>n</sub> output.

When MI911 is set to 1, the channel's position compare register is tied to the first encoder counter on the ASIC -- Encoder 1 for channels 1-4, Encoder 5 for channels 5-8, or Encoder 9 for channels 9-10 - and the position compare signal appears both on EQU<sub>n</sub>, and combined into the EQU output for the first channel on the IC (EQU1 or EQU5); executed as a logical OR.

MI911 for the first channel on an ASIC performs no effective function, so is always 1. It cannot be set to 0.

**MI912** determines which signal or combination of signals, and which polarity, triggers a position capture of the counter for the encoder mapped to the specified node. If a flag input (home, limit, or user) is used, MI913 for the node determines which flag. Proper setup of this variable is essential for a successful home search, which depends on the position-capture function. The following settings may be used:

- 0:     Capture under software control (armed)
- 1:     Capture on Index (CHC<sub>n</sub>) high

- 2: Capture on Flag high
- 3: Capture on (Index high AND Flag high)
- 4: Capture under software control (latched)
- 5: Capture on Index (CHCn) low
- 6: Capture on Flag high
- 7: Capture on (Index low AND Flag high)
- 8: Capture under software control (armed)
- 9: Capture on Index (CHCn) high
- 10: Capture on Flag low
- 11: Capture on (Index high AND Flag low)
- 12: Capture under software control (latched)
- 13: Capture on Index (CHCn) low
- 14: Capture on Flag low
- 15: Capture on (Index low AND Flag low)

The trigger is armed when the position capture register is read. After this, as soon as the Compact MACRO Station sees that the specified input lines are in the specified states, the trigger will occur -- it is level-trigger, not edge-triggered.

**MI913** parameter determines which of the "Flag" inputs will be used for position capture (if one is used -- see MI912):

- 0: HMFLn (Home Flag n)
- 1: PLIMn (Positive End Limit Flag n)
- 2: MLIMn (Negative End Limit Flag n)
- 3: USERn (User Flag n)

Typically, this parameter is set to 0 or 3, because in actual use the LIMn flags create other effects that usually interfere with what is trying to be accomplished by the position capture. If you wish to capture on the LIMn flags, probably you will want to disable their normal functions with Ix25, or use a channel n where none of the flags is used for the normal axis functions.

### Output Mode Select (MSn, MI916)

The ACC-24E2 family of boards can be used for multiple mode outputs. At the MACRO Station, the user must set up the output mode on MACRO Station variable MSn,MI916. The table below shows the output modes available for each of the ACC24E2 boards. The output modeselect will be set up automatically if using either the P2Setup or Turbo Setup programs

Board	Direct PWM Mode	DAC Mode	Pulse and Direction
ACC-24E2	Yes	No	Yes
ACC-24E2A	No	Yes	Yes
ACC-24E2S	No	No	Yes

The PMAC2 Style outputs allow the PMAC to control up to 3 individual output channels based on the mode. These outputs are described as output A, output B, and output C.

MSn, MI916	Output Description	Typical Use
0	A, B, and C are PWM	Direct PWM Mode Only
1	A and B are DAC C is PWM	±10V Outputs for torque, velocity and sinusoidal input ampli
2	A and B are PWM C is PFM	Stepper Systems
3	A and B are DAC C is PFM	±10V Outputs with MLDT Feedback

The default output at the MACRO Station is PWM (MSn,I916=0).

### MACRO Station Encoder Conversion Table (MSn,MI120–MI151)

At power-up, the MACRO Station will set up automatically all of the key memory locations and MI-Variables based on the SW1 connector and firmware of the MACRO Station. The key variables set up at power-up are the encoder conversion table, servo output registers, and flag input registers.

#### Encoder Conversion Table for ACC-24E2 at MACRO Station

```

MS0,MI120=$00C040 ;output at X:$0010 at MACRO Station (encoder 1)
MS0,MI121=$00C048 ;output at X:$0011 at MACRO Station (encoder 2)
MS0,MI122=$00C050 ;output at X:$0012 at MACRO Station (encoder 3)
MS0,MI123=$00C058 ;output at X:$0013 at MACRO Station (encoder 4)
MS0,MI120=$00C060 ;output at X:$0014 at MACRO Station (encoder 5)
MS0,MI121=$00C068 ;output at X:$0015 at MACRO Station (encoder 6)
MS0,MI122=$00C070 ;output at X:$0016 at MACRO Station (encoder 7)
MS0,MI123=$00C078 ;output at X:$0017 at MACRO Station (encoder 8)
    
```



## MLDT FEEDBACK FOR UMAC-TURBO & UMAC-MACRO

---

---

The ACC-24E2A can provide direct interface to magnetostrictive linear displacement transducers (MLDTs) through its encoder connectors. This interface is for MLDTs with an “external excitation” format (often called “RS-422 format”) because of the signal levels, because the ACC-24E2A provides the excitation pulse, and receives the echo pulse, both with RS-422 signal formats.

This section provides basic information for using MLDTs with the ACC-24E2A. More general information can be found in the User’s Manuals for the Turbo PMAC or the MACRO Station.

### MLDT Hardware Setup of the ACC-24E2A

---

The ACC-24E2A must be set up by the user to output the differential pulse on what are normally the “T” and “W” input flags on the encoder connector. This is done by putting jumpers on E-points E1C and E1D for the first channel on the board, or E2C and E2D for the second channel on the board. These jumpers are OFF by default.

The PULSE+ (high during the pulse) and PULSE- (low during the pulse) outputs from the encoder connector are connected to the differential pulse inputs on the MLDT. The echo pulse differential outputs from the MLDT are connected to the CHA+ and CHA- input pins on the same encoder connector.

If the MLDT uses “RPM” format, in which there is a brief “start” echo pulse, and a brief “stop” echo pulse, the “+” output from the MLDT should be connected to the CHA+ input on the ACC-24E2A, and the “-” output should be connected to the CHA- input.

If the MLDT uses “DPM” format, in which there is a single long echo pulse, with the delay to the trailing edge measuring the position, the “+” output from the MLDT should be connected to the CHA- input on the ACC-24E2A, and the “-” output should be connected to the CHA+ input.

### MLDT Software Setup of the UMAC Turbo

---

When the ACC-24E2A is used for MLDT feedback in a UMAC Turbo system, there are a few I-variables that must be set up properly.

#### Hardware Setup I-Variables for Servo IC m

- **I7m03 (PFM Clock Frequency):** In almost all cases, the clock frequency driving the pulse-generation circuitry for all channels on Servo IC m can be left at its default value of 9.83 MHz (0.102 µsec). Few people will need to change I7m03, which also controls other clock signals, from its default value of 2258.

- **I7m04 (PFM Pulse Width):** The pulse width, set by I7m04 in units of PFM clock cycles must be set long enough for the MLDT to see, and long enough to “contain” the rising edge of the RPM “start” echo pulse, or the rising edge of the single DPM echo pulse. For example, if this edge can come up to 2 μsec after the start of the excitation pulse, and the PMAC clock cycle is at its default of about 0.1 μsec, then I7m04 must be set at least to 20.
- **I7mn6 (Output Format Select):** For Servo IC m Channel n to be used for MLDT feedback, I7mn6 must be set to 1 or 3 for the “C” sub-channel to be used for PFM-format output. On an ACC-24E2A, I7mn6 must then be set to 3 for the “A” and “B” sub-channels to be used for DAC-format output.
- **I7mn0 (MLDT Feedback Select):** For Servo IC m Channel n to be used for MLDT feedback, I7mn0 must be set to 12. In this mode, the pulse timer is cleared on the output pulse, and latched on the echo pulse, counting in between at 117.96 MHz.

### Conversion Table Processing I-Variables

The pulse timer for Servo IC m Channel n holds a number proportional to the time and therefore the position. This must be processed in the conversion table before it can be used by the servo loop. It is best to use the “filtered parallel data” conversion, a 3-line entry in the table (three consecutive I-variables).

- **Line 1 (Method and Address):** This 24-bit value (6 hex digits) should begin with a “3” (filtered parallel data) followed by the address of the timer register. The possible values for this line are shown in the following table:

Encoder Conversion Table Parallel Filtered Data Format 1<sup>st</sup> Line  
For ACC-24E2A Boards with Servo IC m Channel n

ACC-24 #	Servo IC #	Channel 1	Channel 2	Channel 3	Channel 4
1A	2	\$378200	\$378208	\$378210	\$378218
1B	3	\$378300	\$378308	\$378310	\$378318
2A	4	\$379200	\$379208	\$379210	\$379218
2B	5	\$379300	\$379308	\$379310	\$379318
3A	6	\$37A200	\$37A208	\$37A210	\$37A218
3B	7	\$37A300	\$37A308	\$37A310	\$37A318
4A	8	\$37B200	\$37B208	\$37B210	\$37B218
4B	9	\$37B300	\$37B308	\$37B310	\$37B318

- **Line 2 (Width and Start):** This 24-bit value should be set to \$013000 to specify the use of 19 bits (\$013) starting at bit 0.
- **Line 3 (Max Change):** This 24-bit value should be set to a value slightly greater than the maximum true velocity ever expected, expressed in timer LSBs per servo cycle. With a typical MLDT, the 117.96 MHz timer LSB represents 0.024 mm (0.00094 inches); the default servo cycle is 0.442 msec.

The result of this conversion is in the X-register of the third line. Any functions using this value should address this register. For example, if this were the first entry in the table, which starts at \$003501, the result would be in X:\$003503.

## Motor I-Variables

- **Ixx03 (Position Loop Feedback Address):** To use the result of the conversion table for position-loop feedback for Motor xx, Ixx03 should contain the address of the result register in the conversion table - \$003503 in the above example.
- **Ixx04 (Velocity Loop Feedback Address):** To use the result of the conversion table for velocity-loop feedback for Motor xx, Ixx04 should contain the address of the result register in the conversion table - \$003503 in the above example.
- **Ixx05 (Master Position Address):** To use the result of the conversion table for the master position for Motor xx, Ixx05 should contain the address of the result register in the conversion table - \$003503 in the above example.
- **Ixx10 and Ixx95 (Power-On Position Address and Format):** To use the MLDT for absolute power-on position for Motor xx, Ixx95 should be set to \$180000 (up to 24 bits of parallel Y-data) and Ixx10 should be set to the address of the timer register used:

Ixx10 for ACC-24E2A MLDT Timer Registers (Ixx95=\$180000)

ACC-24 #	Servo IC #	Channel 1	Channel 2	Channel 3	Channel 4
1A	2	\$078200	\$078208	\$078210	\$078218
1B	3	\$078300	\$078308	\$078310	\$078318
2A	4	\$079200	\$079208	\$079210	\$079218
2B	5	\$079300	\$079308	\$079310	\$079318
3A	6	\$07A200	\$07A208	\$07A210	\$07A218
3B	7	\$07A300	\$07A308	\$07A310	\$07A318
4A	8	\$07B200	\$07B208	\$07B210	\$07B218
4B	9	\$07B300	\$07B308	\$07B310	\$07B318

- **Ixx80 (Power-On Mode):** Set Ixx80 to 4 to delay the absolute power-on position read until the pulse-output frequency can be set.
- **Ixx81 and Ixx91 (Power-On Phase Position Address and Format):** Occasionally the MLDT is used to establish an absolute phase reference position for Turbo-PMAC-commutated motors. In this case, Ixx81 and Ixx91 are set to the same values as Ixx10 and Ixx95, respectively (see above).

## Pulse Output Frequency

The pulse-output frequency is established by assigning an M-variable to the “C” sub-channel command register, and writing a value to that M-variable after every power-up/reset. The suggested M-variable for the Motor xx using this register is:

Mxx07->Y: {address}, 8, 16, S

where {address} is specified according to the following table:

Mxx07 for ACC-24E2A MLDT Pulse-Output Registers

ACC-24 #	Servo IC #	Channel 1	Channel 2	Channel 3	Channel 4
1A	2	\$078204	\$07820C	\$078214	\$07821C
1B	3	\$078304	\$07830C	\$078314	\$07831C
2A	4	\$079204	\$07920C	\$079214	\$07921C
2B	5	\$079304	\$07930C	\$079314	\$07931C
3A	6	\$07A204	\$07A20C	\$07A214	\$07A21C
3B	7	\$07A304	\$07A30C	\$07A314	\$07A31C
4A	8	\$07B204	\$07B20C	\$07B214	\$07B21C
4B	9	\$07B304	\$07B30C	\$07B314	\$07B31C

The frequency of the pulse output should produce a period just slightly longer than the longest expected response time for the echo pulse. For MLDTs, the response time is approximately 0.35 µsec/mm (9 µsec/inch). On an MLDT 1500 mm (~60 in) long, the longest response time is approximately 540 µsec; a recommended period between pulse outputs for this device is 600 µsec, for a frequency of 1667 Hz.

To produce the desired pulse output frequency, the following formula can be used (assuming a 16-bit M-variable definition):

$$OutputFreq(kHz) = \frac{Mxx07}{65,536} PFMCLK\_Freq(kHz)$$

or:

$$Mxx07 = 65,536 * \frac{OutputFreq(kHz)}{PFMCLK\_Freq(kHz)}$$

To produce a pulse output frequency of 1.667 kHz with the default PFMCLK frequency of 9.83 MHz, we calculate:

$$Mxx07 = 65,536 * \frac{1.667}{9,380} \cong 11$$

To write this value to the register, a power-on PLC routine is suggested; this can also be done with on-line commands from the host computer. Sample PLC code to do this for Channel 1, using the above example value, is:

```

OPEN PLC 1           ; PLC 1 is first program to execute
CLEAR
  M107=11           ; Set pulse frequency
  CMD"$*"          ; Absolute Position Read
DISABLE PLC 1       ; So will not execute again
CLOSE
  
```

## **PMAC2/Turbo PMAC2 Conversion Table & Motor I-variables**

Once the MACRO Station has been set up to process the MLDT feedback, the PMAC2 or Turbo PMAC2 can process the ongoing position feedback with its conversion table, Ix03, and Ix04 just as for any other feedback from a MACRO Station.

If the MLDT is used for absolute power-on position for the servo loop, the proper variables must be set on the PMAC2 or Turbo PMAC2:

- **PMAC2 Ix10 (Power-On Position Address and Format):** To get the absolute position in this format for Motor x through MACRO node “n” (n = 0 to 15 decimal), Ix10 should be set to \$74000n, where “n” here is the hexadecimal representation of the node number (n = 0 to F hex).
- **Turbo PMAC2 Ixx10 & Ixx95 (Power-On Position Address and Format):** To get the absolute position for Motor xx through MACRO node “n” (n = 0 to 63 decimal), Ixx10 should be set to “n”; in hex-format \$0000nn, where “nn” is the hexadecimal representation of the node number (nn = 00 to 3F hex). If node 0 is used, Ixx10 should be set to \$000100 (256 decimal). Ixx95 should be set to \$740000 to specify parallel data through a MACRO node.

If the MLDT is used for absolute power-on phase position for commutation, the proper variables must be set on the PMAC2 or Turbo PMAC2:

- **PMAC2 Ix81 (Power-On Phase Position Address and Format):** To get the absolute phase position in this format for Motor x through MACRO node “n” (n = 0 to 15 decimal), Ix81 should be set to \$74000n, where “n” here is the hexadecimal representation of the node number (n = 0 to F hex).
- **Turbo PMAC2 Ixx81 & Ixx91 (Power-On Phase Position Address and Format):** To get the absolute phase position for Motor xx through MACRO node “n” (n = 0 to 63 decimal), Ixx81 should be set to “n”; in hex-format \$0000nn, where “nn” is the hexadecimal representation of the node number (nn = 00 to 3F hex). If node 0 is used, Ixx81 should be set to \$000100 (256 decimal). Ixx91 should be set to \$740000 to specify parallel data through a MACRO node.



## MLDT Feedback for UMAC-MACRO

---

The data from the MLDT is processed as a **parallel word** input at the MACRO Station and then transmitted back to the Ultralite using the traditional Servo Node. The encoder conversion table at the MACRO Station will have to be modified to process this data. From the Ultralite standpoint, nothing will need to be modified to read the position and velocity data.

Since the data is also absolute, the data can also be sent at the Ultralite as absolute data for correct position at power-up. This is accomplished with the proper setup of MSn,MI11x at the MACRO Station, and Ix10 at the Ultralite or Ix10 and Ix95 with the Turbo Ultralite. Regardless of the type of Ultralite, retrieving the power-on-position is the same. The information must be retrieved from MACRO Station variable MSn,MI920 for each node transfer as specified by Ix10 at the Ultralite. The user does not have to setup MSn,MI920 because the MACRO Station will place the power-on position the appropriate register at power-up.

### MLDT Software Setup of the UMAC MACRO

When the ACC-24E2A is used for MLDT feedback in a UMAC MACRO system, there are a few MI-variables in the MACRO Station, and a few in the PMAC2 or Turbo PMAC2 driving the Station, that must be set up properly.

### Station Hardware Setup I-Variables for Servo IC

- **MS{anynode},MI903/MI907 (PFM Clock Frequency):** In almost all cases, the clock frequency driving the pulse-generation circuitry for all channels on the Servo IC can be left at its default value of 9.83 MHz (0.102  $\mu$ sec). Few people will need to change MI903/MI907, which also controls other clock signals, from its default value of 2258.
- **MS{anynode},MI904/MI908 (PFM Pulse Width):** The pulse width, set by MI904/MI908 in units of PFM clock cycles must be set long enough for the MLDT to see, and long enough to “contain” the rising edge of the RPM “start” echo pulse, or the rising edge of the single DPM echo pulse. For example, if this edge can come up to 2  $\mu$ sec after the start of the excitation pulse, and the PMAC clock cycle is at its default of about 0.1  $\mu$ sec, then I7m04 must be set at least to 20.
- **MS{node},MI916 (Output Format Select):** For the channel associated with this node to be used for MLDT feedback, MI916 must be set to 1 or 3 for the “C” sub-channel to be used for PFM-format output. On an ACC-24E2A, I7mn6 must then be set to 3 for the “A” and “B” sub-channels to be used for DAC-format output.
- **MS{node},MI910 (MLDT Feedback Select):** For the channel associated with this node to be used for MLDT feedback, MI910 must be set to 12. In this mode, the pulse timer is cleared on the output pulse, and latched on the echo pulse, counting in between at 117.96 MHz.

### Station Conversion Table Processing I-Variables

The pulse timer for Servo IC m Channel n holds a number proportional to the time and therefore the position. This must be processed in the conversion table before it can be used by the servo loop. It is best to use the “filtered parallel data” conversion, a 3-line entry in the table (three consecutive MI-variables). The MI-variables for the conversion table start at MI120.

- **Line 1 (Method and Address):** This 24-bit value (6 hex digits) should begin with a “3” (filtered parallel data) followed by the address of the timer register. The possible values for this line are shown in the following table:

Encoder Conversion Table Parallel Filtered Data Format 1<sup>st</sup> Line  
For ACC-24E2A Boards

ACC-24 #	Channel 1	Channel 2	Channel 3	Channel 4
1	\$30C040	\$30C048	\$30C050	\$30C058
2	\$30C060	\$30C068	\$30C070	\$30C078

- **Line 2 (Bits Used Mask):** This 24-bit value should be set to \$07FFFF to specify the use of the low 19 bits of the 24-bit source word.
- **Line 3 (Max Change):** This 24-bit value should be set to a value slightly greater than the maximum true velocity ever expected, expressed in timer LSBs per servo cycle. With a typical MLDT, the 117.96 MHz timer LSB represents 0.024 mm (0.00094 inches); the default servo cycle is 0.442 msec.

The result of this conversion is in the X-register of the third line. Any functions using this value should address this register. For example, if this were the first entry in the table, which starts at \$000010, the result would be in X:\$0012.

### Station Motor Node I-Variables

- **MS{anynode}, MI10x (“xth” Motor Node Position Loop Feedback Address):** To use the result of the conversion table for position-loop feedback for the “xth” motor node, MI10x should contain the address of the result register in the conversion table - \$0012 in the above example.
- **MS{anynode}, MI11x (“xth” Motor Node Absolute Position Address):** To use the MLDT for absolute power-on position for the “xth” motor node, MI11x should be set to \$18xxxx (up to 24 bits of parallel Y-data) from Station address “xxxx”, where “xxxx” is the address of the timer register.

MS{anynode},MI11x “xth” Motor Node Absolute Position

ACC-24 #	Channel 1	Channel 2	Channel 3	Channel 4
1	\$30C042	\$30C04A	\$30C052	\$30C05A
2	\$30C062	\$30C06A	\$30C072	\$30C07A

- **MS{anynode}, MI16x (“xth” Motor Node MLDT Frequency Control):** This variable establishes the frequency of the excitation pulse sent to the MLDT. Its value is automatically written to the full 24-bit “C” sub-channel command register for the channel assigned to this node, so the PFM circuit will create a pulse train at this frequency.

To compute the output frequency as a function of MI16x, the following formula can be used:

$$OutputFreq(kHz) = \frac{MI16x}{16,777,216} PFMCLK\_Freq(kHz)$$

To compute the required value of MI16x as a function of the desired output frequency, the following formula can be used:

$$MI16x = 16,777,216 * \frac{OutputFreq(kHz)}{PFMCLK\_Freq(kHz)}$$

### Power-On Feedback Address for PMAC2 Ultralite

Both the Ultralite and the Turbo Ultralite allow the user to obtain absolute position at power up or upon request (#n\$\*). The Ultralite must have Ix10 setup and the Turbo Ultralite needs both Ixx10 and Ixx95 setup to enable this power on position function. For power on position reads as specified in this document MACRO firmware version 1.114 or newer is needed, the Turbo Ultralite firmware must be 1.936 or newer, and lastly the standard Ultralite users must have firmware version 1.16H or newer.

Ix10 permits an automatic read of an absolute position sensor at power-on/reset. If Ix10 is set to 0, the power-on/reset position for the motor will be considered to be 0, regardless of the type of sensor used. There are specific settings of PMAC’s/PMAC2’s Ix10 for each type of MACRO interface. If a Turbo Ultralite is used, Ixx95 must also be set appropriately. The Compact MACRO Station has a corresponding variable I11x for each node that must be set.

### Absolute Position for Ultralite

Compact MACRO Station Feedback Type (firmware version 1.16H and above)	Ix10 (Unsigned)	Ix10 (Signed)
ACC-8D Opt 7 Resolver/Digital Converter	\$73000n	\$F3000n
ACC-8D Opt 9 Yaskawa Absolute Encoder Converter	\$72000n	\$F2000n
ACC-8D Opt 10 Sanyo Absolute Encoder Converter	\$74000n	\$F4000n
ACC-28B or ACC-28E Analog/Digital Converter	\$74000n	\$F4000n
MACRO Station Option 1C/ACC-6E A/D Converter	\$74000n	\$F4000n
MACRO Station Parallel Input	\$74000n	\$F4000n
MACRO Station MLDT Input	\$74000n	\$F4000n

‘n’ is the MACRO node number used for Motor x: 0, 1, 4, 5, 8, 9, C(12), or D(13).

### Absolute Position for Turbo Ultralite

(Ixx95=\$720000 - \$740000, \$F20000 - \$F40000)

Addresses are MACRO Node Numbers

MACRO Node Number	Ixx10 for MACRO IC 0	Ixx10 for MACRO IC 1	Ixx10 for MACRO IC 2	Ixx10 for MACRO IC 3
0	\$000100	\$000010	\$000020	\$000030
1	\$000001	\$000011	\$000021	\$000031
4	\$000004	\$000014	\$000024	\$000034
5	\$000005	\$000015	\$000025	\$000035
8	\$000008	\$000018	\$000028	\$000038
9	\$000009	\$000019	\$000029	\$000039
12	\$00000C	\$00001C	\$00002C	\$00003C
13	\$00000D	\$00001D	\$00002D	\$00003D

Compact MACRO Station Feedback Type	Ixx95 (Unsigned)	Ixx95 (Signed)
ACC-8D Opt 7 Resolver/Digital Converter	\$730000	\$F30000
ACC-8D Opt 9 Yaskawa Absolute Encoder Converter	\$720000	\$F20000
ACC-8D Opt 10 Sanyo Absolute Encoder Converter	\$740000	\$F40000
ACC-28B Analog/Digital Converter	\$740000	\$F40000
MACRO Station Option 1C/ACC-6E A/D Converter	\$740000	\$F40000
MACRO Station Parallel Input, MLDT, SSI	\$740000	\$F40000

When PMAC or PMAC2 has Ix10 set to get absolute position over MACRO, it executes a station auxiliary read command MS{node},I920 to request the absolute position from the Compact MACRO Station. The station then references its own I11x value to determine the type, format, and address of the data to be read.

### MACRO Parallel Absolute Position Setup

MI111 through MI118 (MI11x) specify whether, where, and how absolute position is to be read on the Compact MACRO Station for a motor node (MI11x controls the xth motor node, which usually corresponds to Motor x on PMAC) and sent back to the Ultralite.

If MI11x is set to 0, no power-on reset absolute position value will be returned to PMAC. If MI11x is set to a value greater than 0, then when the PMAC requests the absolute position because its Ix10 and/or Ix81 values are set to obtain absolute position through MACRO (sending an auxiliary **MS{node},MI920** command), the Compact MACRO Station will use MI11x to determine how to read the absolute position, and report that position back to PMAC as an auxiliary response.

For an MLDT, we must take the output from the encoder conversion table (ECT) at the MACRO Station and process it as an absolute position because the information in the ECT is synchronized properly. Remember, the output from the encoder conversion table will reside in the X register. For example, if we had the following entry:

MS0,MI120=\$30C040 (\$10 of ECT)

MS0,MI121=\$FFFFFF (\$11 of ECT)

MS0,MI122=32 (\$12 of ECT)

The output from the ECT will reside in X:\$12 and this will be the register we will obtain the absolute data from.

MI11x consists of two parts. The low 16 bits (last 4 hexadecimal digits) specify the address on the MACRO Station from which the absolute position information is read. The high 8 bits (first 2 hexadecimal digits) tell the Compact MACRO Station how to interpret the data at that address (the “method”).

**MACRO MI11x Parallel Word Example: Signed 24-bit Absolute MLDT \$0010**

HEX(\$)	D				8				0				0				1				0			
BIT	23	22	21	20	19	18	17	16	15	14	13	12	11	10	9	8	7	6	5	4	3	2	1	0
VALUE	1	1	0	1	1	0	0	0	0	0	0	0	0	0	0	0	0	0	0	1	0	0	0	0

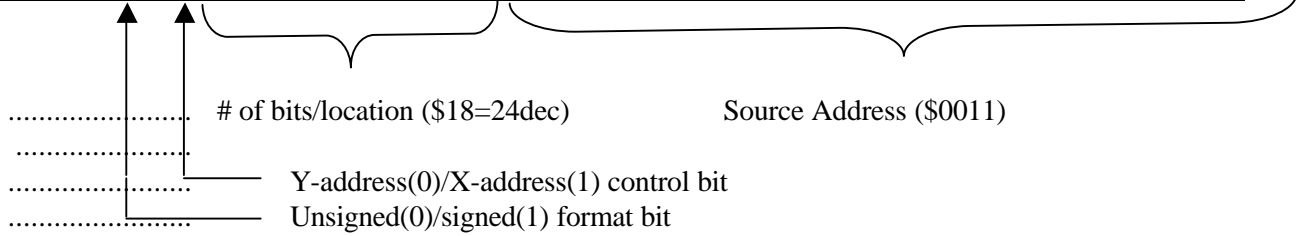

*X/Y Address Bit:* If bit 22 of Ix10 is 0, the PMAC looks for the parallel sensor in its Y address space. This is the standard choice, since all I/O ports map into the Y address space. If this bit is 1, PMAC looks for the parallel sensor in its X address space.

*Signed/Unsigned Bit:* If the most significant bit (MSB -- bit 23) of MI11x is 0, the value read from the absolute sensor is treated as an unsigned quantity. If the MSB is 1, which adds \$80 to the high 8 bits of MI11x, the value read from the sensor is treated as a signed, two's-complement quantity.

```
MS0,MI111=$D80010 ;read signed 24-bit absolute power on position from X:$0010
```

*Example MLDT Setup for UMAC-MACRO*

Ultralite	Turbo Ultralite	Description
I110=\$740000	I110=\$000100 I195=\$740000	Power on position read from MACRO Node 0 as an unsigned value

```
MS0,i161=3825 ;(15*255)
MS0,i903=2258 ;default
MS0,I904=25 ;might need to increase from factory default

MS0,I910=12
MS0,I916=3

MS0,i120=$30C040
MS0,I121=$FFFFFF ;24-bit
MS0,I122=32 ;output at $12

MS0,i101=$12
MS0,i111=$D80010 ;grab data from 1st entry of ECT X register
```



## ACC-24E2A TERMINAL BLOCK DESCRIPTION

The terminal blocks on the ACC-24E2A are described as TB1 Top, TB2 Top, TB3 Top, TB1 Bottom, TB2 Bottom, TB3 Bottom, TB1 Front and TB2 Front. The top connectors have the Encoder signals, the bottom connectors have the Amplifier signals, and the front connectors contain the Limit and Flag signals.

### Connector TB1 TOP - ENCODER 1

Pin#	Symbol	Function	Description	Notes
1	CHA1+	Input	Enc 1 Pos. A Chan.	
2	CHA1-	Input	Enc 1 Neg. A Chan.	
3	CHB1+	Input	Enc 1 Pos. B Chan.	
4	CHB1-	Input	Enc 1 Neg. B Chan.	
5	CHC1+	Input	Enc 1 Pos. C Chan.	Index channel
6	CHC1-	Input	Enc 1 Neg. C Chan.	Index channel
7	ENCPWR	Output	Digital Supply	Power for encoder
8	GND	Common	Digital Reference	
9	CHU1+/DIR_1+	I/O	Supplemental Flag U or Direction 1+	Also Direction Output
10	CHV1+/DIR_1-	I/O	Supplemental Flag V or Direction 1-	Also Direction Output
11	CHW1+/PUL_1+	I/O	Supplemental Flag W or Pulse Output 1+	Also Pulse Output
12	CHT1+/PUL_1-	I/O	Supplemental Flag T or Pulse Output 1-	Also Pulse Output

## Connector TB2 Top - Encoder 2

Pin#	Symbol	Function	Description	Notes
1	CHA2+	Input	Enc 2 Pos. A Chan.	
2	CHA2-	Input	Enc 2 Neg. A Chan.	
3	CHB2+	Input	Enc 2 Pos. B Chan.	
4	CHB2-	Input	Enc 2 Neg. B Chan.	
5	CHC2+	Input	Enc 2 Pos. C Chan.	Index channel
6	CHC2-	Input	Enc 2 Neg. C Chan.	Index channel
7	ENCPWR	Output	Digital Supply	Power for encoder
8	GND	Common	Digital Reference	
9	CHU1+/DIR_2+	I/O	Supplemental Flag U or Direction 2+	Also Direction Output
10	CHV1+/DIR_2-	I/O	Supplemental Flag V or Direction 2-	Also Direction Output
11	CHW1+/PUL_2+	I/O	Supplemental Flag W or Pulse Output 2+	Also Pulse Output
12	CHT1+/PUL_2-	I/O	Supplemental Flag T or Pulse Output 2-	Also Pulse Output

## Connector TB3 Top – EQU Outputs

Pin#	Symbol	Function	Description	Notes
1	GND	Common	Reference Voltage	
2	BEQU1	Output	Compare output1	
3	BEQU2	Output	Compare output2	

## Connector TB1 Bottom Amp – Out 1

Pin#	Symbol	Function	Description	Notes
1	DAC1A+	Output	Phase A Analog Out	+/-10V, ref to AGND
2	DAC1A-	Output	Phase A Analog Out	-/+10V; ref to AGND
3	DAC1B+	Output	Phase B Analog Out	+/-10V, ref to AGND
4	DAC1B-	Output	Phase B Analog Out	-/+10V; ref to AGND
5	AE_NC_1	Output	Amplifier Enable	Normally Closed
6	AE_COM_1	Input	Amplifier Enable	
7	AE_NO_1	Output	Amplifier Enable	Normally Open
8	AFAULT_1+	Input		
9	AFAULT_1-	Input		
10	AA+15V	Input*	Analog Positive Supply Voltage	Remove jumpers E85, E87, E88 if using external power
11	AA-15V	Input*	Analog Negative Supply Voltage	Remove jumpers E85, E87, E88 if using external power
12	AAGND	Input*	Analog Reference Voltage	Remove jumpers E85, E87, E88 if using external power

\*External power supply inputs for opto-isolation from the digital ground plane.

### Connector TB2 Bottom Amp – Out 2

Pin#	Symbol	Function	Description	Notes
1	DAC2A+	Output	Phase A Analog Out	+/-10V, ref to AGND
2	DAC2A-	Output	Phase A Analog Out	-/+10V; ref to AGND
3	DAC2B+	Output	Phase B Analog Out	+/-10V, ref to AGND
4	DAC2B-	Output	Phase B Analog Out	-/+10V; ref to AGND
5	AE_NC_2	Output	Amplifier Enable	Normally Closed
6	AE_COM_2	Output	Amplifier Enable	
7	AE_NO_2	Output	Amplifier Enable	Normally Open
8	AFAULT_2+	Input		
9	AFAULT_2-	Input		
10	AA+15V	Input*	Aanalog Positive Supply Voltage	Remove jumpers E85, E87, E88 if using external power
11	AA-15V	Input*	Aanalog Negative Supply Voltage	Remove jumpers E85, E87, E88 if using external power
12	AAGND	Input*	Analog Reference Voltage	Remove jumpers E85, E87, E88 if using external power

\* External power supply inputs for opto-isolation from the digital ground plane.

### Connector TB3 Bottom – Analog Power

Pin#	Symbol	Function	Description	Notes
1	AAGND	Input*	Analog Reference Voltage	Remove jumpers E85, E87, E88 if using external power
2	AA+15V	Input*	Analog Positive Supply Voltage	Remove jumpers E85, E87, E88 if using external power
3	AA-15V	Input*	Analog Negative Supply Voltage	Remove jumpers E85, E87, E88 if using external power

\* External power supply inputs for opto-isolation from the digital ground plane.

### Connector TB1 FRONT- LIMITS 1

Pin#	Symbol	Function	Description	Notes
1	USER1	Input	General Capture Flag	Sinking or sourcing
2	PLIM1	Input	Positive Limit Flag	Sinking or sourcing
3	MLIM1	Input	Negative Limit Flag	Sinking or sourcing
4	HOME1	Input	Home Flag	Sinking or sourcing
5	FLG_1_RET	Input	Return For All Flags	+V (12 To 24v) or 0v

## Connector TB2 FRONT- LIMITS 2

Pin#	Symbol	Function	Description	Notes
1	USER2	Input	General Capture Flag	Sinking or sourcing
2	PLIM2	Input	Positive Limit Flag	Sinking or sourcing
3	MLIM2	Input	Negative Limit Flag	Sinking or sourcing
4	HOME2	Input	Home Flag	Sinking or sourcing
5	FLG_2_RET	Input	Return For All Flags	+V (12 To 24v) or 0v

## ACC-24E2 OPTION 1A TERMINAL BLOCK DESCRIPTION

The terminal blocks on the ACC-24E2 option 1A are described as TB1 Top, TB2 Top, TB3 Top, TB1 Bottom, TB2 Bottom, TB3 Bottom, TB1 Front and TB2 Front. The top connectors have the Encoder signals, the bottom connectors have the Amplifier signals, and the front connectors contain the Limit and Flag signals.

### Connector TB1 TOP - ENCODER 3

Pin#	Symbol	Function	Description	Notes
1	CHA3+	Input	Enc 3 Pos. A Chan.	Also pulse input
2	CHA3-	Input	Enc 3 Neg. A Chan.	Also pulse input
3	CHB3+	Input	Enc 3 Pos. B Chan.	Also direction iInput
4	CHB3-	Input	Enc 3 Neg. B Chan.	Also direction input
5	CHC3+	Input	Enc 3 Pos. C Chan.	Index channel
6	CHC3-	Input	Enc 3 Neg. C Chan.	Index channel
7	ENCPWR	Output	Digital Supply	Power for encoder
8	GND	Common	Digital Reference	
9	CHU3+/DIR_3+	I/O	Supplemental Flag U or Direction 3+	Also Direction Output
10	CHV3+/DIR_3-	I/O	Supplemental Flag V or Direction 3-	Also Direction Output
11	CHW3+/PUL_3+	I/O	Supplemental Flag W or Pulse Output 3+	Also Pulse Output
12	CHT3+/PUL_3-	I/O	Supplemental Flag T or Pulse Output 3-	Also Pulse Output

## Connector TB2 Top – Encoder 4

Pin#	Symbol	Function	Description	Notes
1	CHA4+	Input	Enc 4 Pos. A Chan.	
2	CHA4-	Input	Enc 4 Neg. A Chan.	
3	CHB4+	Input	Enc 4 Pos. B Chan.	
4	CHB4-	Input	Enc 4 Neg. B Chan.	
5	CHC4+	Input	Enc 4 Pos. C Chan.	Index channel
6	CHC4-	Input	Enc 4 Neg. C Chan.	Index channel
7	ENCPWR	Output	Digital Supply	Power for encoder
8	GND	Common	Digital Reference	
9	CHU1+/DIR_4+	I/O	Supplemental Flag U or Direction 4+	Also Direction Output
10	CHV1+/DIR_4-	I/O	Supplemental Flag V or Direction 4-	Also Direction Output
11	CHW1+/PUL_4+	I/O	Supplemental Flag W or Pulse Output 4+	Also Pulse Output
12	CHT1+/PUL_4-	I/O	Supplemental Flag T or Pulse Output 4-	Also Pulse Output

## Connector TB3 Top – EQU Outputs

Pin#	Symbol	Function	Description	Notes
1	GND	Common	Reference Voltage	
2	BEQU3	Output	Compare output3	
3	BEQU4	Output	Compare output4	

### Connector TB1 Bottom Amp-Out 3

Pin#	Symbol	Function	Description	Notes
1	DAC3A+	Output	Phase A Analog out	+/-10V, ref to AGND
2	DAC3A-	Output	Phase A Analog out	-/+10V; ref to AGND
3	DAC3B+	Output	Phase B Analog out	+/-10V, ref to AGND
4	DAC3B-	Output	Phase B Analog out	-/+10V; ref to AGND
5	AE_NC_3	Output	Amplifier Enable	Normally Closed
6	AE_COM_3	Output	Amplifier Enable	
7	AE_NO_3	Output	Amplifier Enable	Normally Open
8	AFAULT_3+	Input		
9	AFAULT_3-	Input		
10	AA+15V	Input*	Analog Positive Supply Voltage	Remove jumpers E85, E87, E88 if using external power
11	AA-15V	Input*	Analog Negative Supply Voltage	Remove jumpers E85, E87, E88 if using external power
12	AGND	Input*	Analog Reference Voltage	Remove jumpers E85, E87, E88 if using external power

\* External power supply inputs for opto-isolation from the digital ground plane.

### Connector TB2 Bottom Amp-Out 4

Pin#	Symbol	Function	Description	Notes
1	DAC4A+	Output	Phase A Analog out	+/-10V, ref to AGND
2	DAC4A-	Output	Phase A Analog out	-/+10V; ref to AGND
3	DAC4B+	Output	Phase B Analog out	+/-10V, ref to AGND
4	DAC4B-	Output	Phase B Analog out	-/+10V; ref to AGND
5	AE_NC_4	Output	Amplifier Enable	Normally Closed
6	AE_COM_4	Output	Amplifier Enable	
7	AE_NO_4	Output	Amplifier Enable	Normally Open
8	AFAULT_4+	Input		
9	AFAULT_4-	Input		
10	AA+15V	Input*	Analog Positive Supply Voltage	Remove jumpers E85, E87, E88 if using external power
11	AA-15V	Input*	Analog Negative Supply Voltage	Remove jumpers E85, E87, E88 if using external power
12	AAGND	Input*	Analog Reference Voltage	Remove jumpers E85, E87, E88 if using external power

\* External power supply inputs for opto-isolation from the digital ground plane.

### Connector TB3 Bottom-Analog Power

Pin#	Symbol	Function	Description	Notes
1	AAGND	Input	Analog Reference Voltage	Remove jumpers E85, E87, E88 if using external power
2	AA+15V	Input	Analog Positive Supply Voltage	Remove jumpers E85, E87, E88 if using external power
3	AA-15V	Input	Analog Nnegative Supply Vvoltage	Remove jumpers E85, E87, E88 if using external power

\* External power supply inputs for opto-isolation from the digital ground plane.

### Connector TB1 Front - Limits 3

Pin#	Symbol	Function	Description	Notes
1	USER3	Input	General Capture Flag	Sinking or Sourcing
2	PLIM3	Input	Positive Limit Flag	Sinking or Sourcing
3	MLIM3	Input	Negative Limit Flag	Sinking or Sourcing
4	HOME3	Input	Home Flag	Sinking or Sourcing
5	FLG_3_RET	Input	Return for All Flags	+V (12 To 24v) or 0v

### Connector TB2 Front - Limits 4

Pin#	Symbol	Function	Description	Notes
1	USER4	Input	General Capture Flag	Sinking or Sourcing
2	PLIM4	Input	Positive Limit Flag	Sinking or Sourcing
3	MLIM4	Input	Negative Limit Flag	Sinking or Sourcing
4	HOME4	Input	Home Flag	Sinking or Sourcing
5	FLG_4_RET	Input	Return for All Flags	+V (12 To 24v) or 0v

## UBUS PINOUTS

### P1 UBUS (96-PIN HEADER)

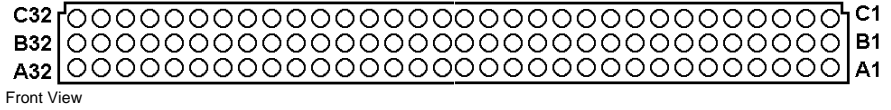

Pin #	Row A	Row B	Row C
1	+5Vdc	+5Vdc	+5Vdc
2	GND	GND	GND
3	BD01	DAT0	BD00
4	BD03	SEL0	BD02
5	BD05	DAT1	BD04
6	BD07	SEL1	BD06
7	BD09	DAT2	BD08
8	BD11	SEL2	BD10
9	BD13	DAT3	BD12
10	BD15	SEL3	BD14
11	BD17	DAT4	BD16
12	BD19	SEL4	BD18
13	BD21	DAT5	BD20
14	BD23	SEL5	BD22
15	BS1	DAT6	BS0
16	BA01	SEL6	BA00
17	BA03	DAT7	BA02
18	BX/Y	SEL7	BA04
19	CS3-	BA06	CS2-
20	BA05	BA07	CS4-
21	CS12-	BA08	CS10-
22	CS16-	BA09	CS14-
23	BA13	BA10	BA12
24	BRD-	BA11	BWR-
25	BS3	MEMCS0-	BS2
26	WAIT-	MEMCS1-	RESET
27	PHASE+	IREQ1-	SERVO+
28	PHASE-	IREQ2-	SERVO-
29	ANALOG	GND IREQ3-	ANALOG GND
30	-15Vdc	PWRGND	+15Vdc
31	GND	GND	GND
32	+5Vdc	+5Vdc	+5Vdc

For more details about the JEXP please see the UBUS Specification Document.





